



COMP9242
Advanced Operating Systems
S2/2014 Week 10:
Multiprocessor OS



Australian Government
Department of Broadband, Communications
and the Digital Economy
Australian Research Council

NICTA Funding and Supporting Members and Partners



Overview



- Multiprocessor OS
 - Scalability (Review)
- Multiprocessor Hardware
 - Contemporary systems
 - Experimental and Future systems
- OS design for Multiprocessors
 - Guidelines
 - Design approaches
 - Divide and Conquer
 - Reduce Sharing
 - No Sharing

MULTIPROCESSOR OS

Uniprocessor OS

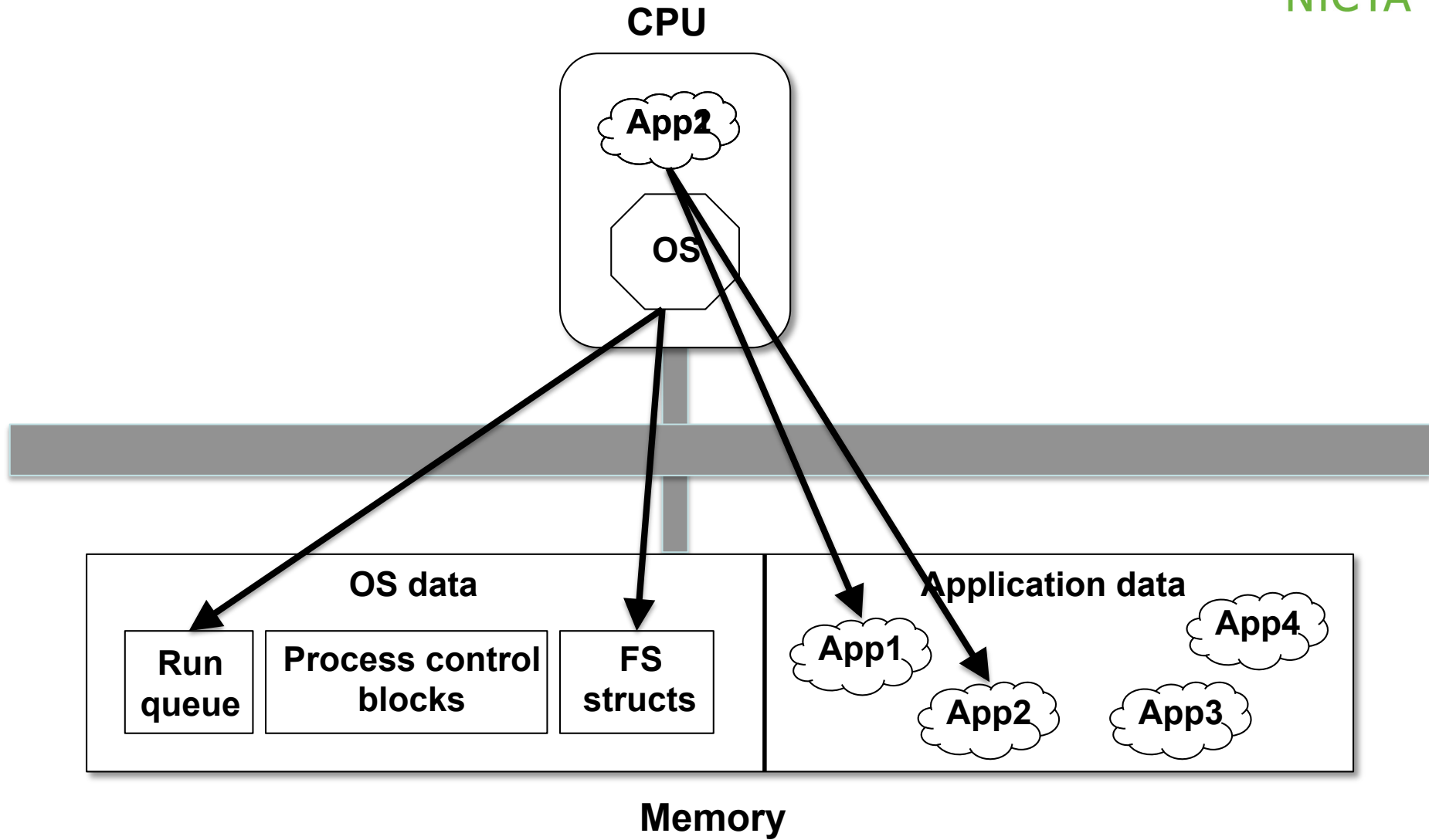

Multiprocessor OS

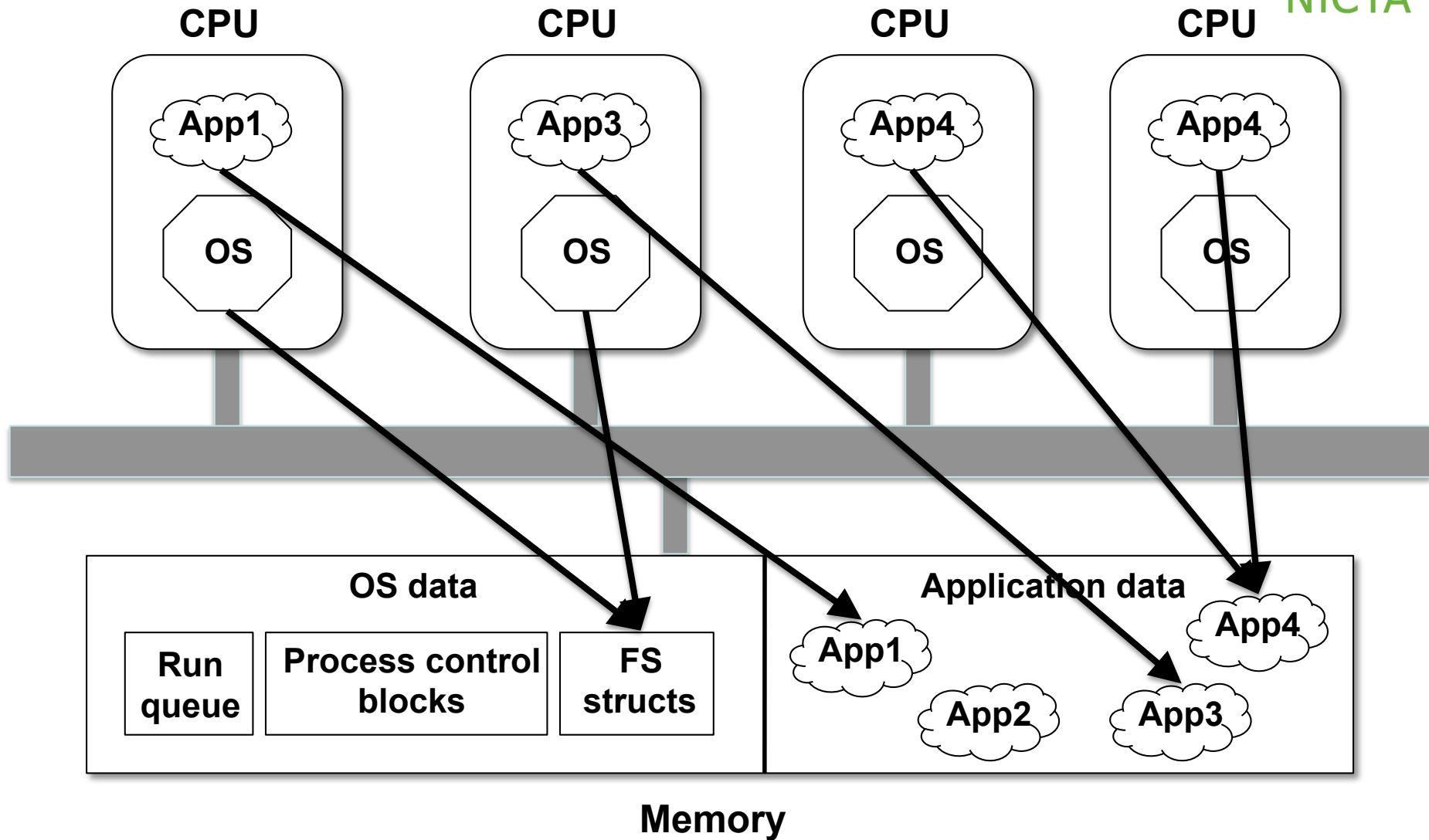

Multiprocessor OS

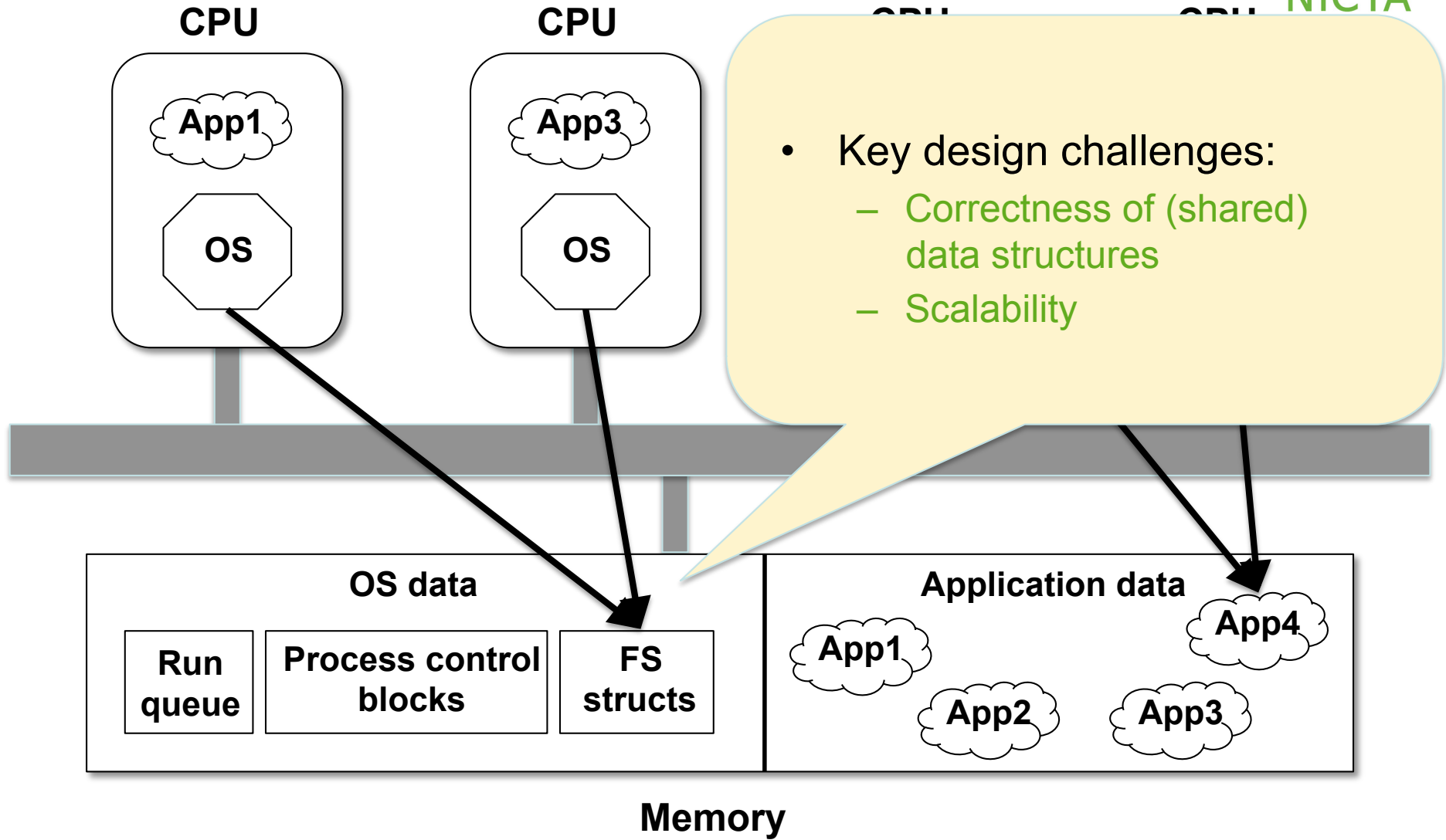

Correctness of Shared Data



- Concurrency control
 - Locks
 - Semaphores
 - Transactions
 - Lock-free data structures
- We know how to do this:
 - In the application
 - In the OS

Scalability



Speedup as more processors added

Ideal

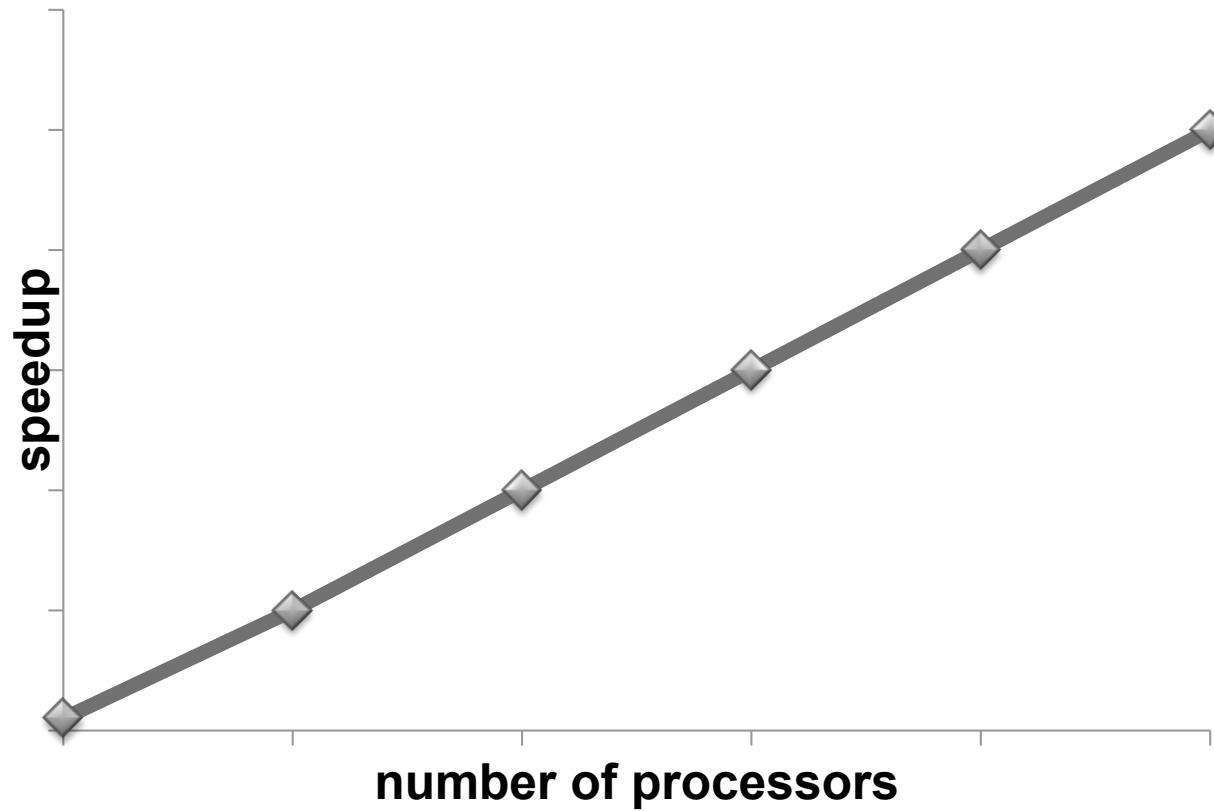

Scalability



Speedup as more processors added

Reality

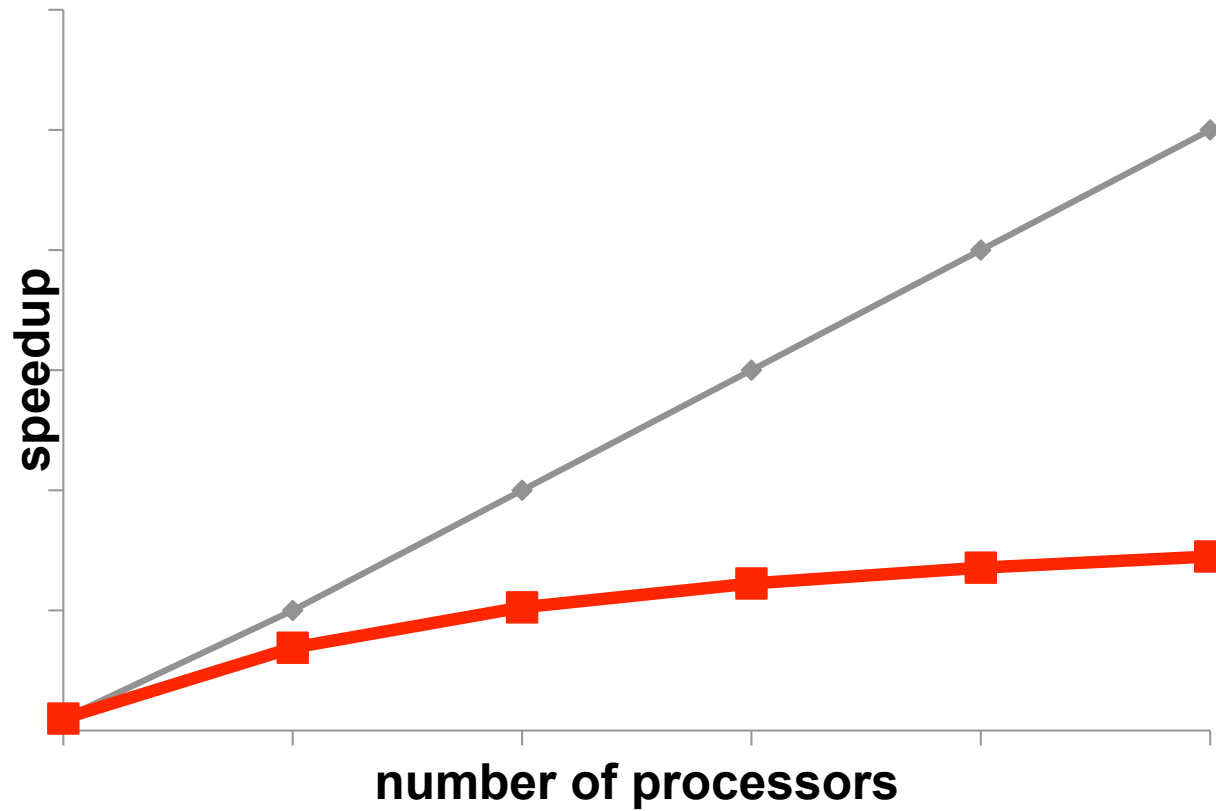

Scalability and Serialisation



Remember Amdahl's law

- Serial (non-parallel) portion: when application not running on all cores
- Serialisation prevents scalability

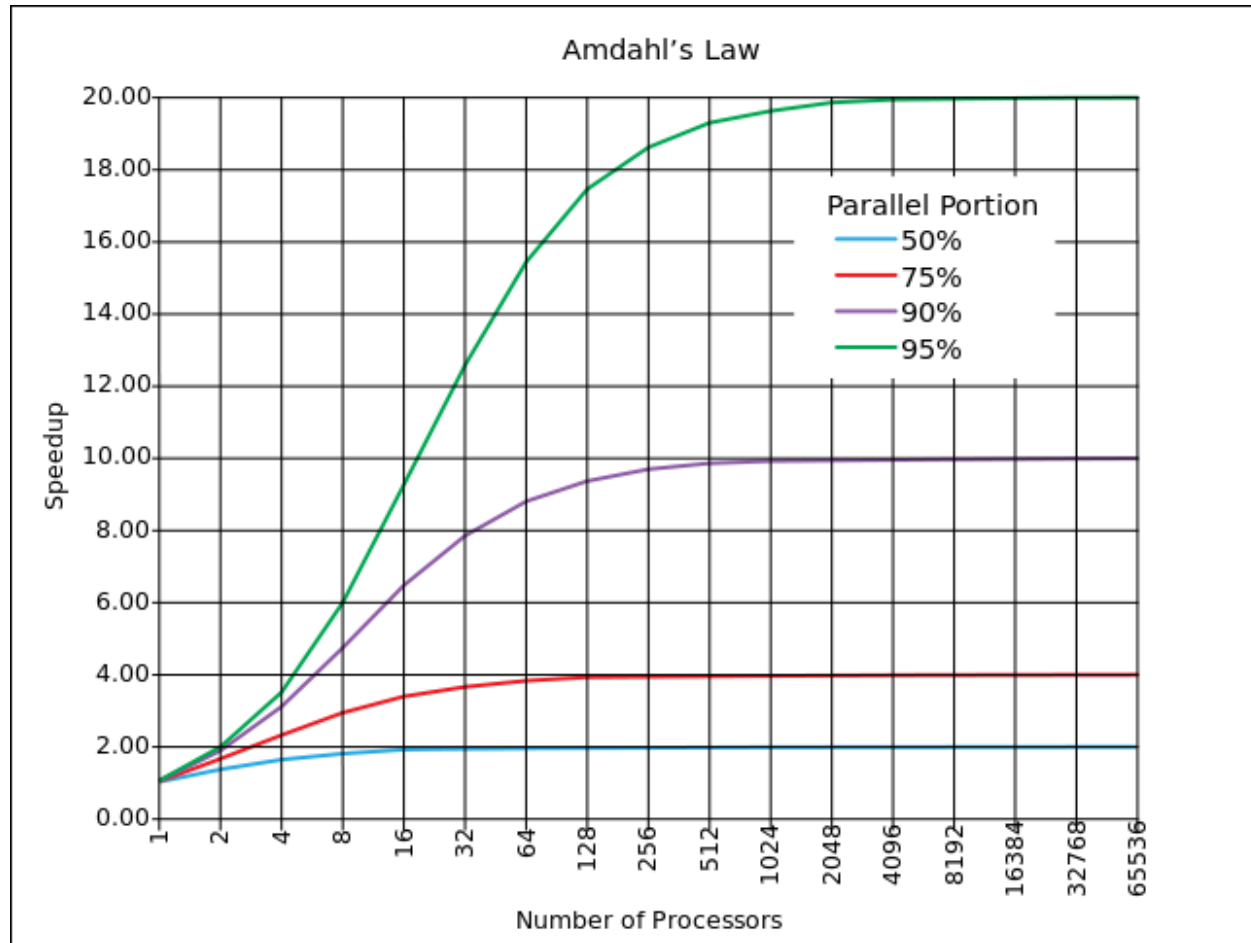

$$S(N) = \frac{1}{(1 - P) + \frac{P}{N}}$$

Serialisation



Where does serialisation show up?

- Application (e.g. access shared app data)
- OS (e.g. performing syscall for app) **How much time is spent in OS?**

Sources of Serialisation:

- Locking (explicit serialisation)
 - **Waiting for a lock** → **stalls self**
 - **Lock implementation:**
 - **Atomic operations lock bus** → **stalls everyone**
 - **Cache coherence traffic loads bus** → **slows down others**
- Memory access (implicit)
 - **Relatively high latency to memory** → **stalls self**
- Cache (implicit)
 - **Processor stalled** while cache line is fetched or invalidated
 - **Affected by latency of interconnect**
 - **Performance depends on data size (cache lines) and contention (number of cores)**

More Cache-related Serialisation



- False sharing
 - Unrelated data structs share the same cache line
 - Accessed from different processors
 - Cache coherence traffic and delay
- Cache line bouncing
 - Shared R/W on many processors
 - E.g: bouncing due to locks: each processor spinning on a lock brings it into its own cache
 - Cache coherence traffic and delay
- Cache misses
 - Potentially direct memory access → stalls self
 - When does cache miss occur?
 - Application runs on new core
 - Cached memory has been evicted

MULTIPROCESSOR HARDWARE

Multi-What?



- Multiprocessor, SMP
 - >1 separate processors, connected by off chip bus
- Multicore
 - >1 processing cores in a single processor, connected by on chip bus
- Multithread, SMT
 - >1 hardware threads in a single core
- Multicore + Multiprocessor
 - >1 multicore processors
 - >1 multicore dies in a package

Interesting Properties of Multiprocessors



- Structure
 - How many cores and processors are there
 - What kinds of cores and processors are there
 - How are they organised
- Interconnect
 - How are the cores and processors connected
- Memory Locality and Caches
 - Where is the memory
 - What is the cache architecture
- Interprocessor Communication
 - How do cores and processors send messages to each other

Contemporary Multiprocessor Hardware



- Intel:
 - Nehalem, Westmere: 10 core, QPI
 - Sandy Bridge, Ivy Bridge:
 - 5 core, ring bus, integrated GPU, L3, IO
 - Haswell (Broadwell):
 - 18 core, ring bus, transactional memory, slices (EP)
- AMD:
 - K10 (Opteron: Barcelona, Magny Cours)
 - 12 core, Hypertransport
 - Bulldozer, Piledriver, Steamroller (Opteron, FX)
 - 16 core, Clustered Multithread: module with 2 integer cores
- Oracle (Sun) UltraSparc T1, T2, T3, T4, T5 (Niagara)
 - 16 cores, 8 threads/core (2 simultaneous), crossbar, 8 sockets
- ARM Cortex A9, A15 MPCore, big.LITTLE
 - 4 -8 cores, big.LITTLE: A7 + A15

Scale and Structure



- ARM Cortex A9 MPCore

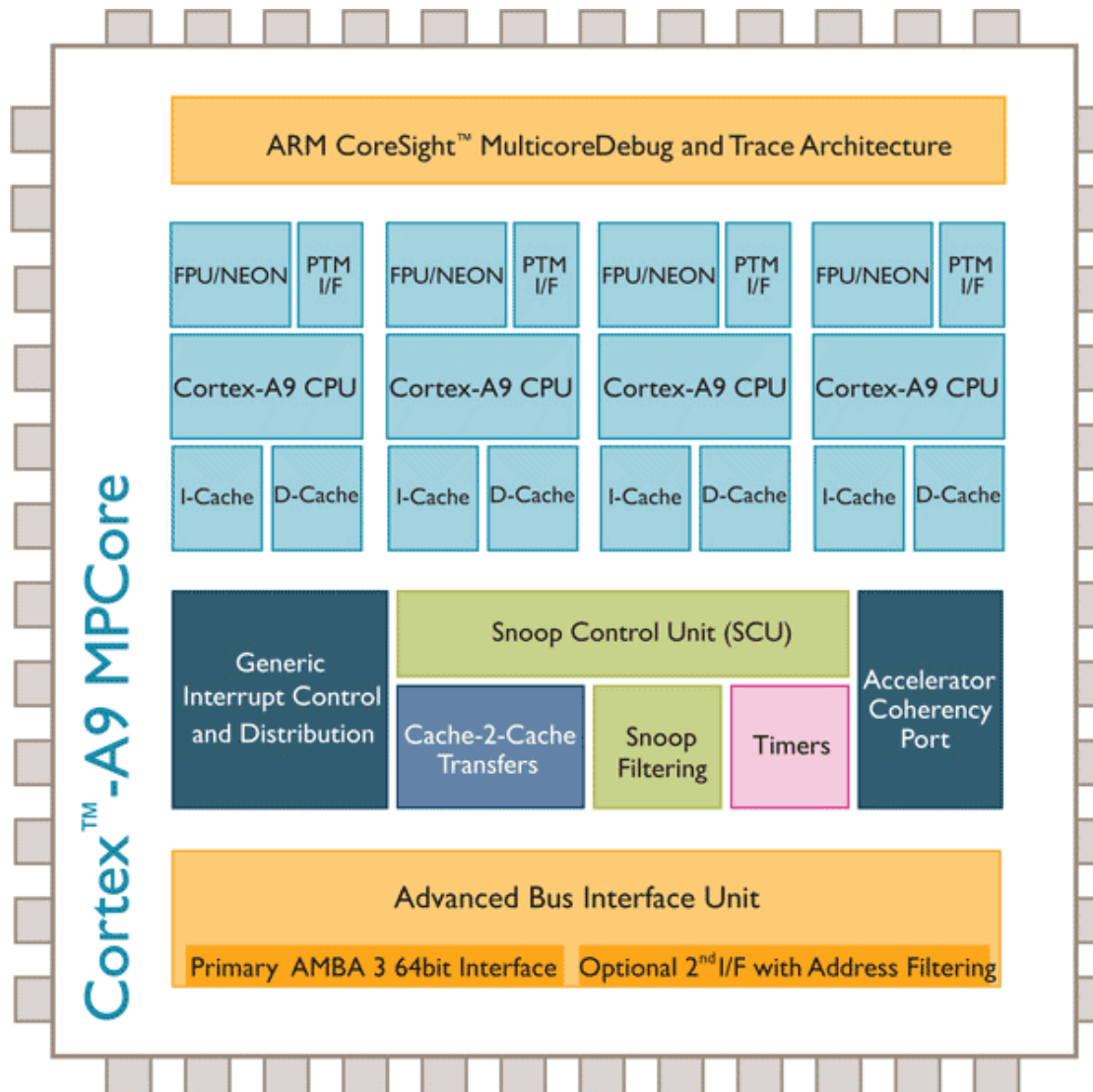

Scale and Structure

- ARM big.LITTLE

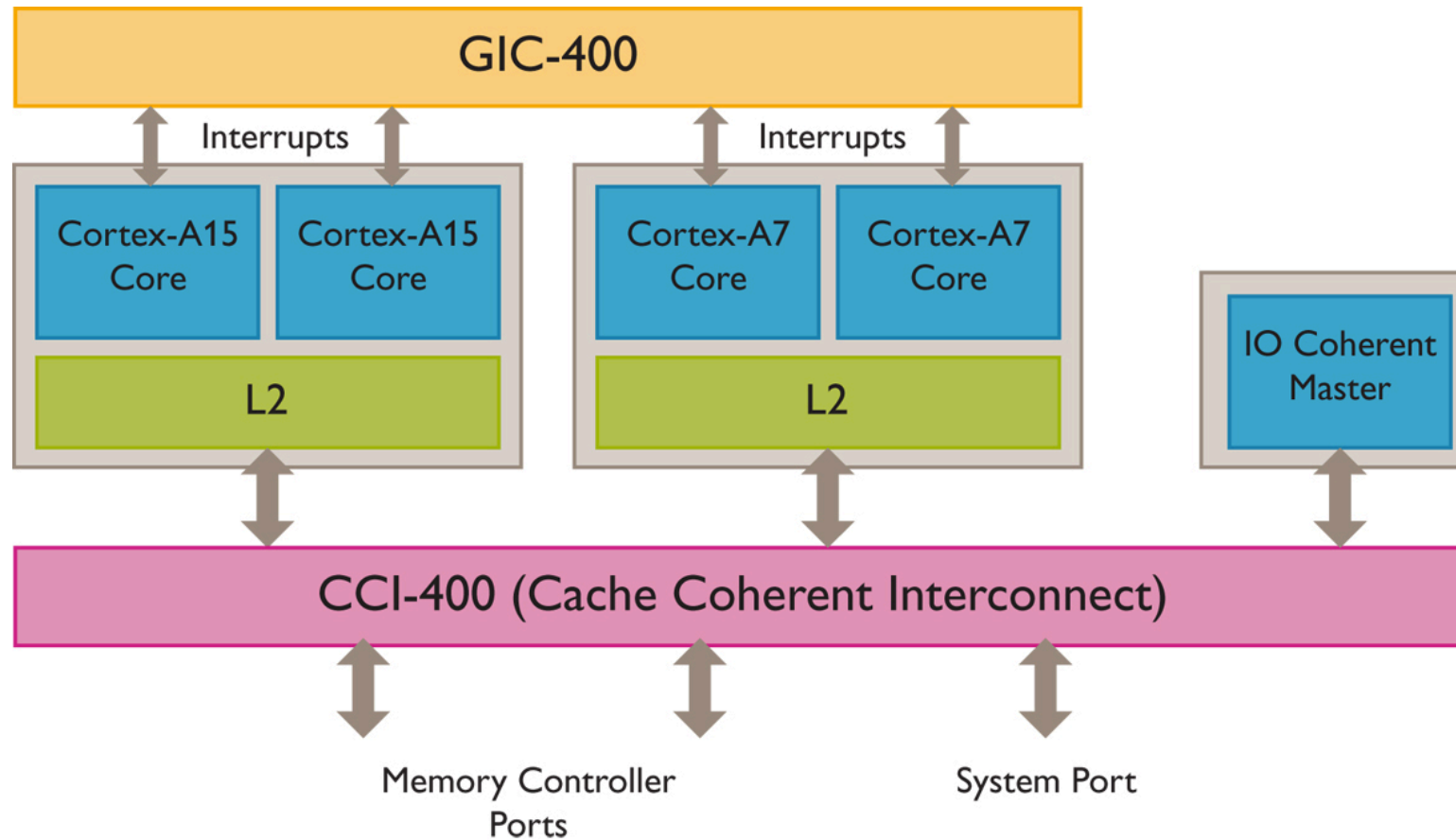

From http://www.arm.com/images/Fig_1_Cortex-A15_CCI_Cortex-A7_System.jpg

Scale and Structure

- Intel Nehalem

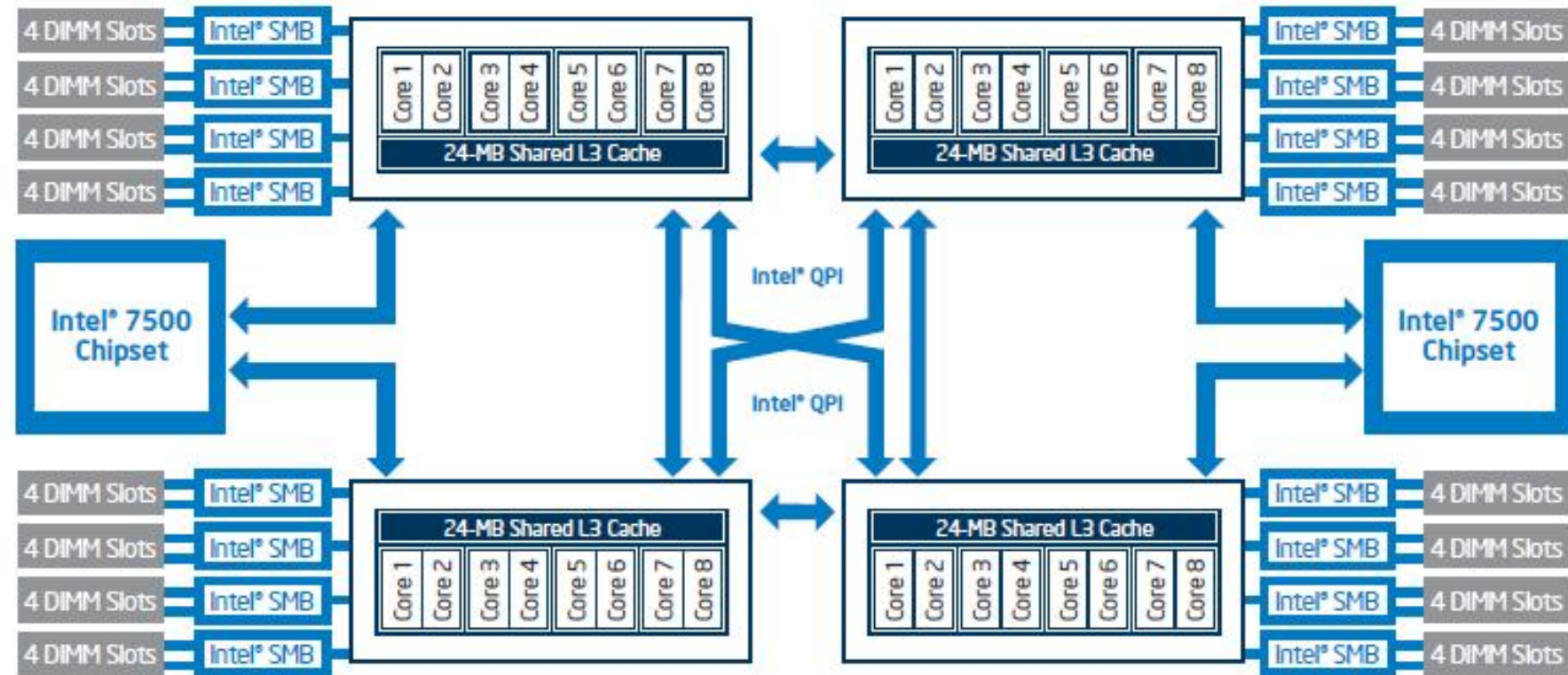

From www.dawnofthered.net/wp-content/uploads/2011/02/Nehalem-EX-architecture-detailed.jpg

Interconnect



- AMD Barcelona

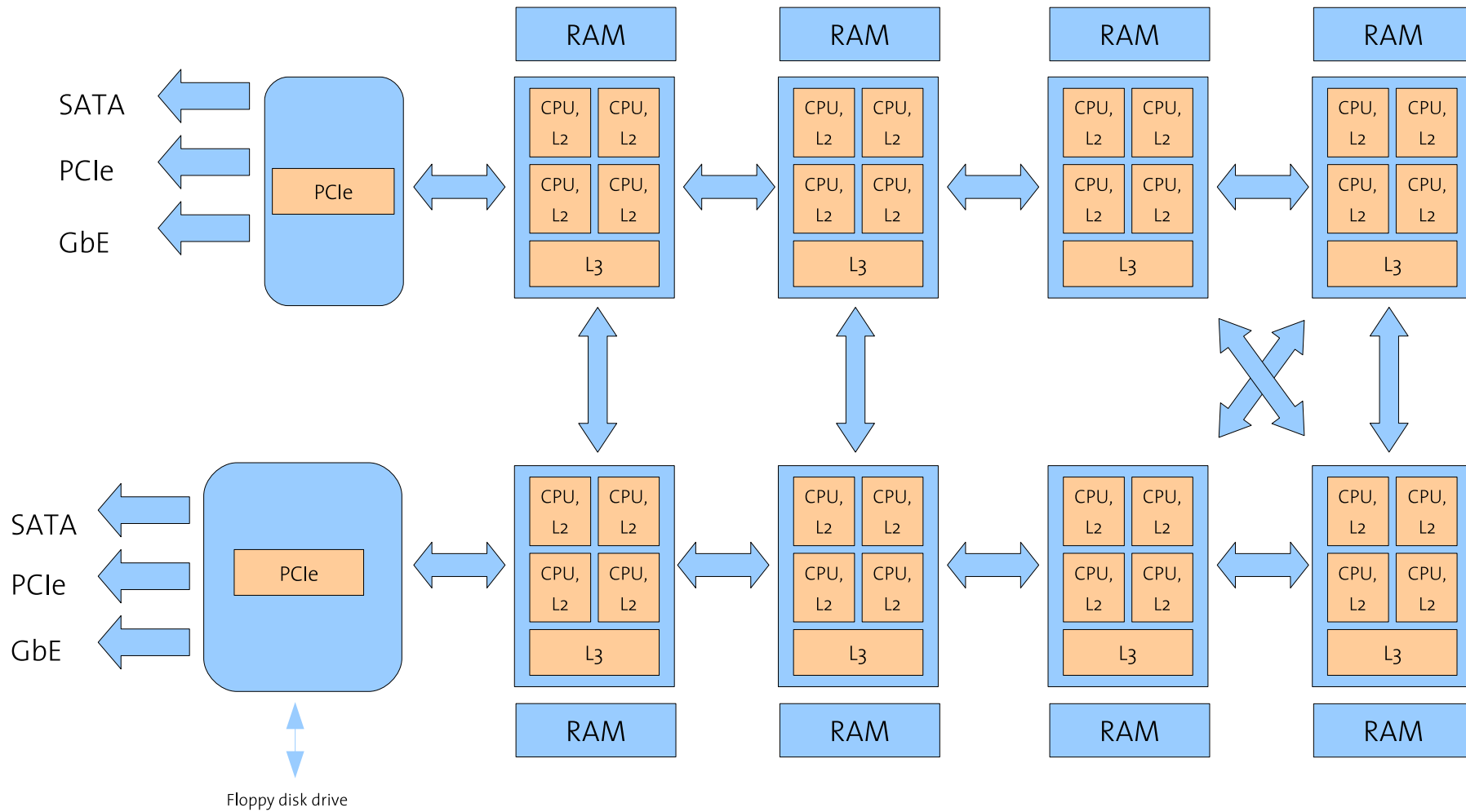

From www.sigops.org/sosp/sosp09/slides/baumann-slides-sosp09.pdf

Memory Locality and Caches

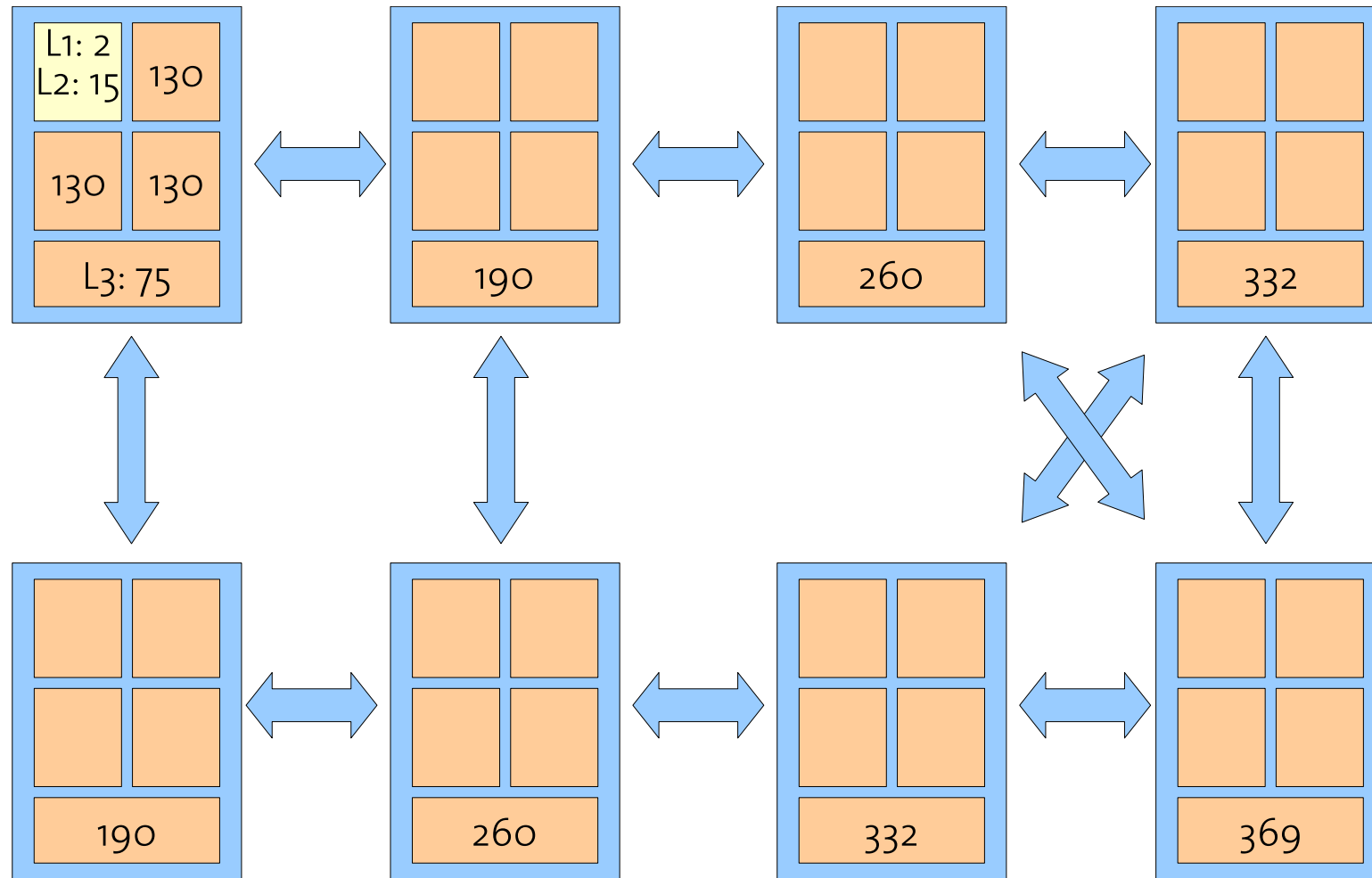

From www.systems.ethz.ch/education/past-courses/fall-2010/aos/lectures/wk10-multicore.pdf

Interprocessor Communication

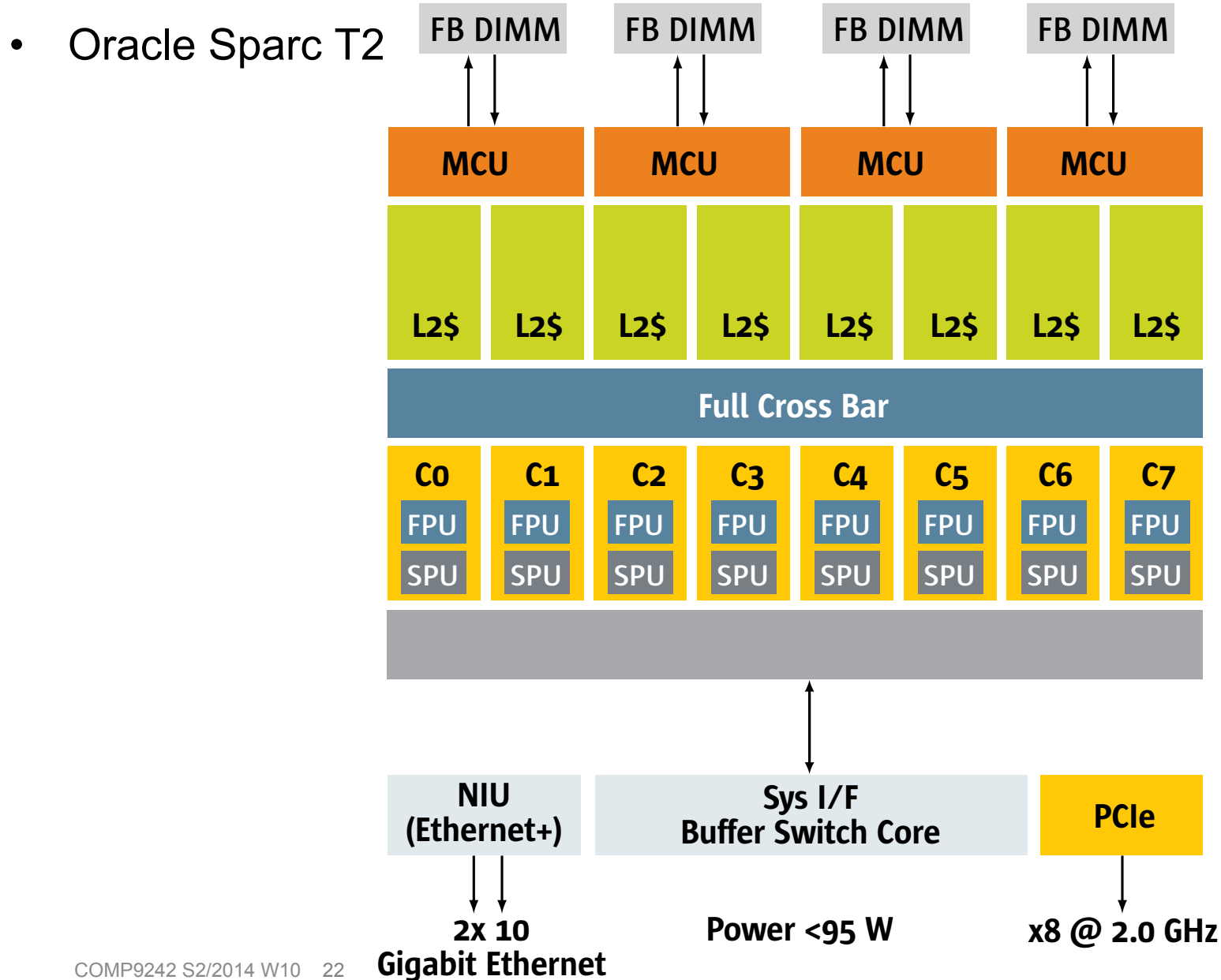

From Sun/Oracle

Interprocessor Communication



Haswell EP Die Configurations

14-18 Core (HCC)

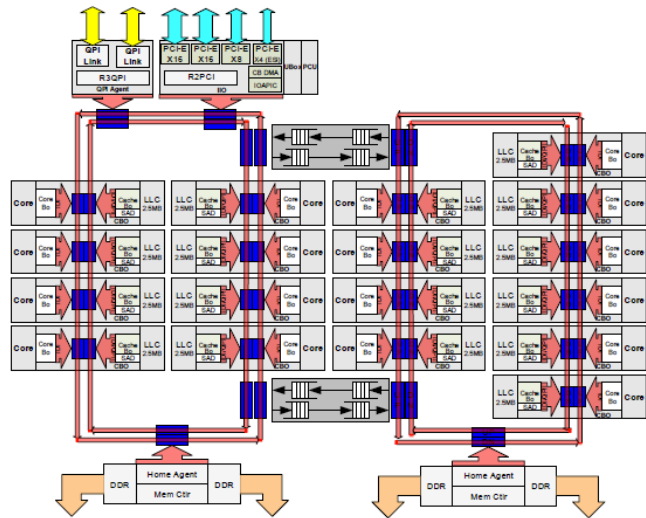

10-12 Core (MCC)

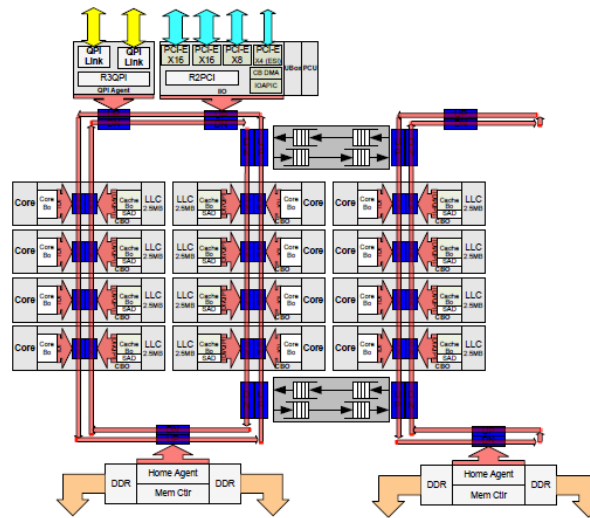

4-8 Core (LCC)

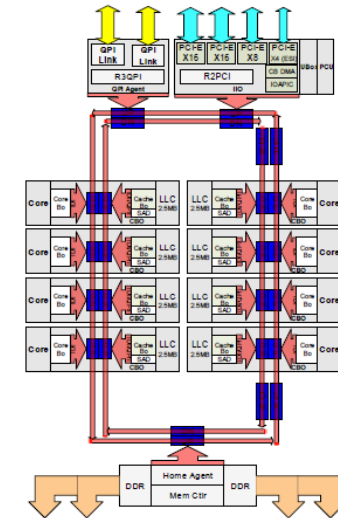

Not representative of actual die-sizes, orientation and layouts – for informational use only.

Chop	Columns	Home Agents	Cores	Power (W)	Transistors (B)	Die Area (mm ²)
HCC	4	2	14-18	110-145	5.69	662
MCC	3	2	6-12	65-160	3.84	492
LCC	2	1	4-8	55-140	2.60	354



From <http://www.anandtech.com/show/8423/intel-xeon-e5-version-3-up-to-18-haswell-ep-cores-4>

Cluster on Die (COD) Mode

- Supported on 1S & 2S SKUs with 2 Home Agents (10+ cores)
- In memory directory bits & directory cache used on 2S to reduce coherence traffic and cache-to-cache transfer latencies
- Targeted at NUMA optimized workloads where latency is more important than sharing across Caching Agents
 - Reduces average LLC hit and local memory latencies
 - HA sees most requests from reduced set of threads potentially offering higher effective memory bandwidth
- OS/VMM own NUMA and process affinity decisions

COD Mode for 18C E5-2600 v3



From <http://www.anandtech.com/show/8423/intel-xeon-e5-version-3-up-to-18-haswell-ep-cores-4>

Experimental/Future Multiprocessor Hardware



- Microsoft Beehive
 - Ring bus, no cache coherence
- Tiler Tile64, Tile-Gx
 - 100 cores, mesh network
- Intel Polaris
 - 80 cores, mesh network
- Intel SCC
 - 48 cores, mesh network, no cache coherency
- Intel MIC (Multi Integrated Core) (Knight's Corner - Xeon Phi)
 - 60+ cores, ring bus

Scale and Structure

- Tileria Tile64, Intel Polaris

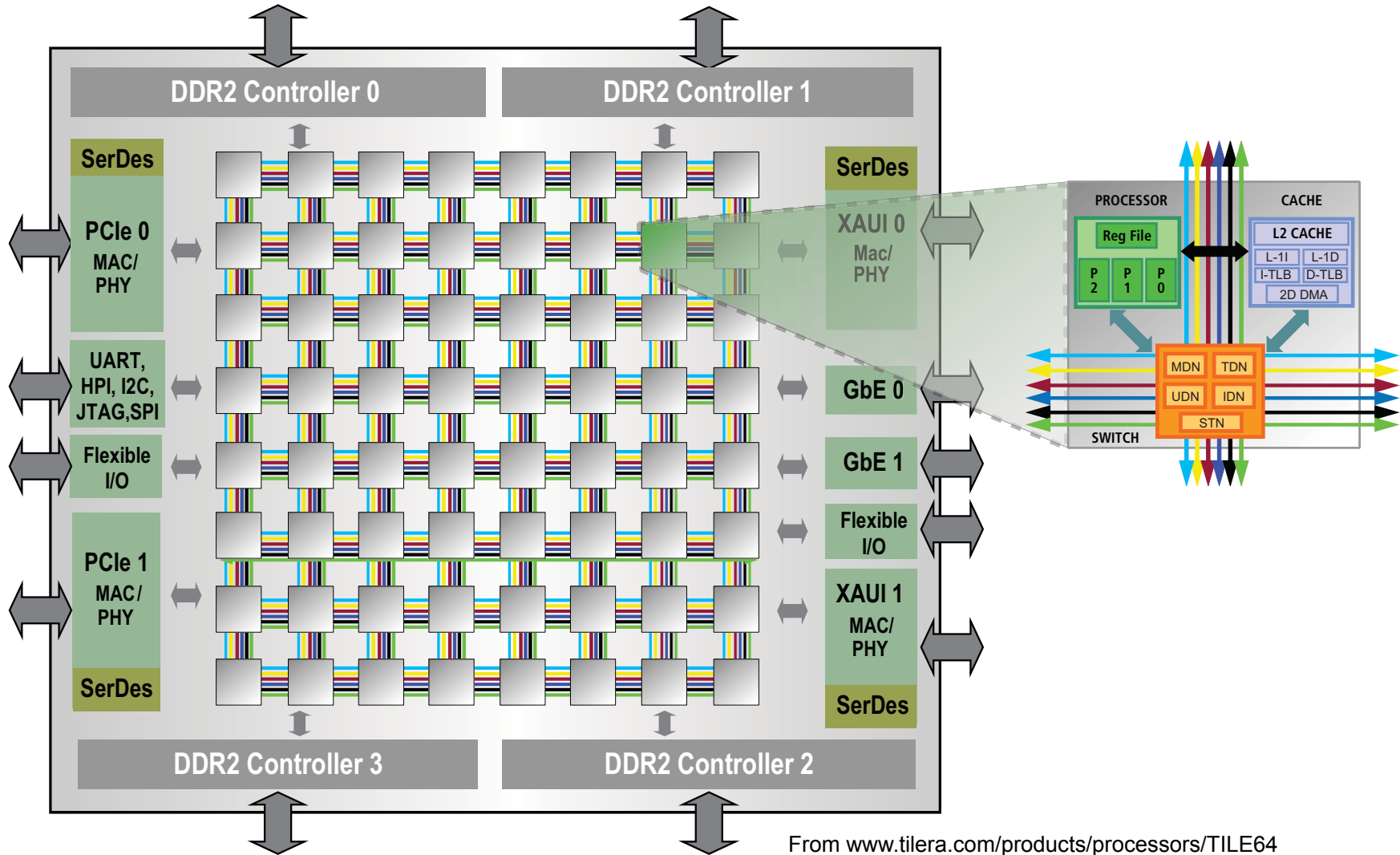

From www.tileria.com/products/processors/TILE64

Cache and Memory

- Intel SCC

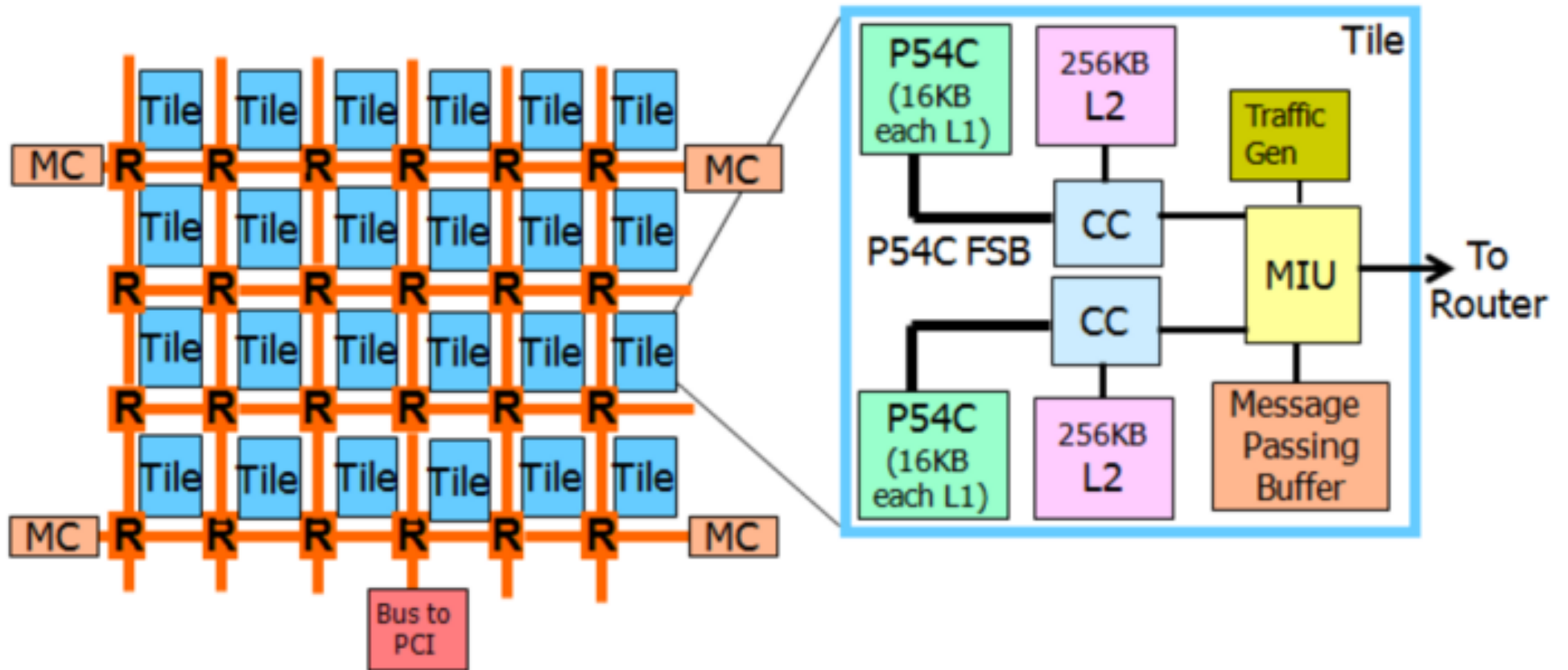

From techresearch.intel.com/spaw2/uploads/files/SCC_Platform_Overview.pdf

Interprocessor Communication



- Beehive

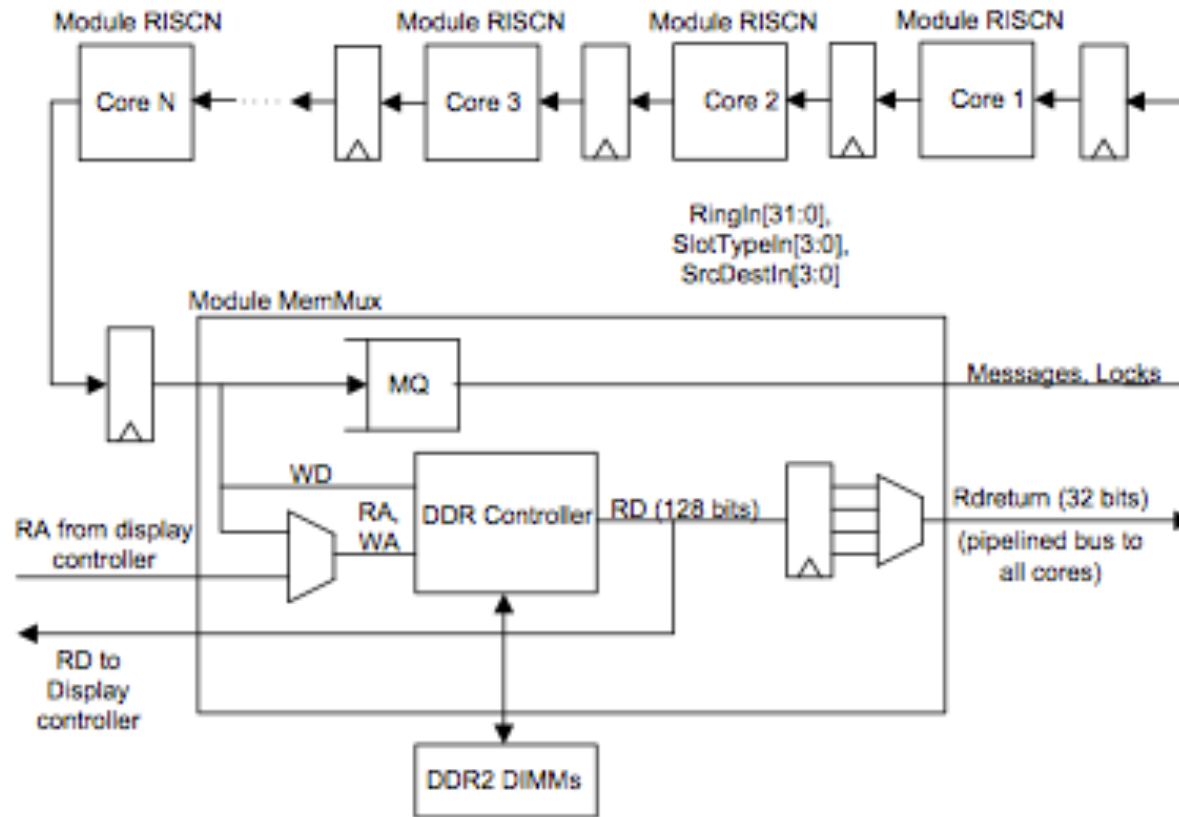

From projects.csail.mit.edu/beehive/BeehiveV5.pdf

Interprocess Communication

- Intel MIC

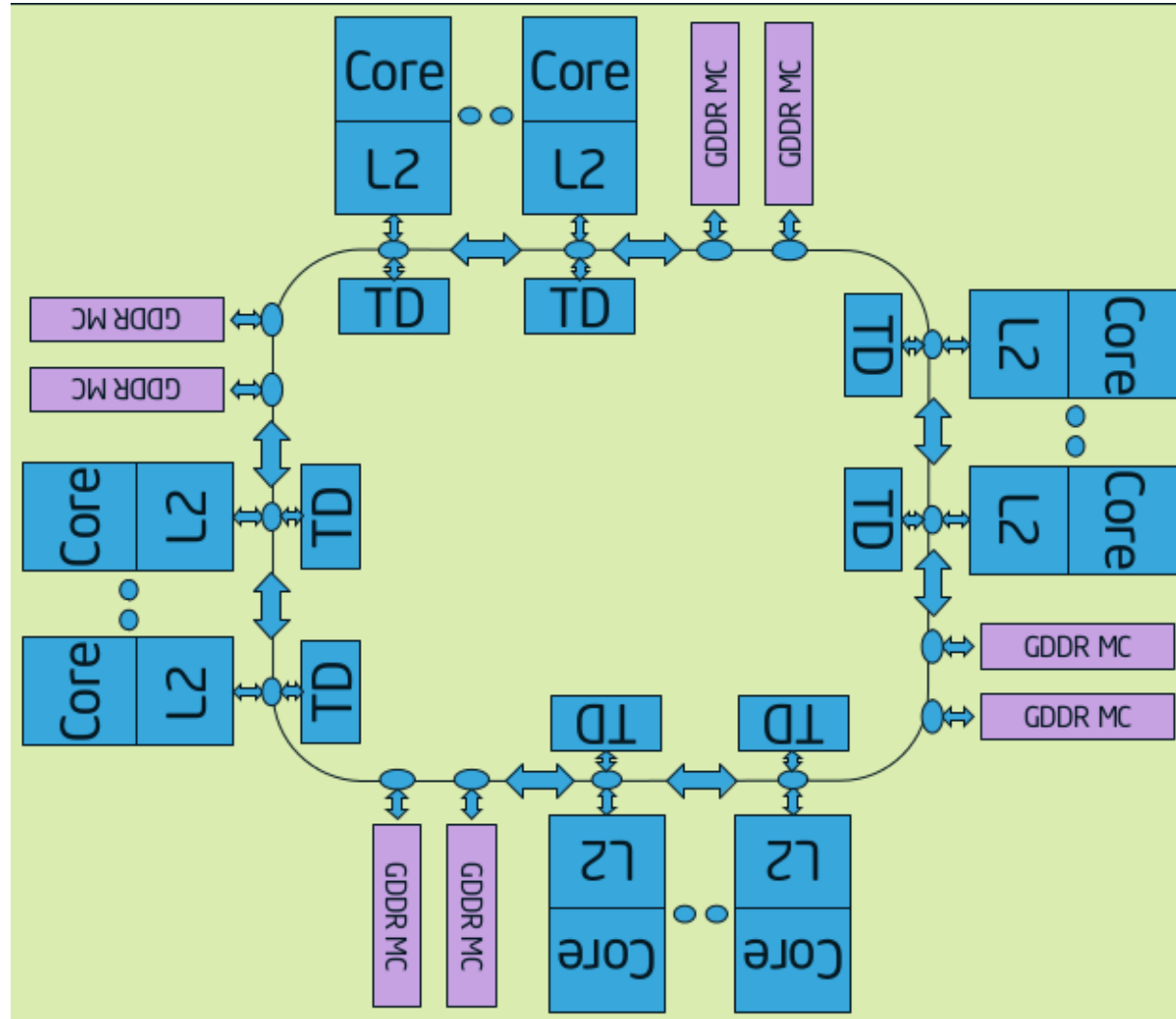

From <http://semiaccurate.com/2012/08/28/intel-details-knights-corner-architecture-at-long-last/>

Summary



- Scalability
 - 100+ cores
 - Amdahl's law really kicks in
- Heterogeneity
 - Heterogeneous cores, memory, etc.
 - Properties of similar systems may vary wildly (e.g. interconnect topology and latencies between different AMD platforms)
- NUMA
 - Also variable latencies due to topology and cache coherence
- Cache coherence may not be possible
 - Can't use it for locking
 - Shared data structures require explicit work
- Computer is a distributed system
 - Message passing
 - Consistency and Synchronisation
 - Fault tolerance

OS DESIGN FOR MULTIPROCESSORS

Optimisation for Scalability



- Reduce amount of code in critical sections
 - Increases concurrency
 - Fine grained locking
 - Lock data not code
 - Tradeoff: more concurrency but more locking (and locking causes serialisation)
 - Lock free data structures
- Avoid expensive memory access
 - Avoid uncached memory
 - Access cheap (close) memory

Optimisation for Scalability



- Reduce false sharing
 - Pad data structures to cache lines
- Reduce cache line bouncing
 - Reduce sharing
 - E.g: MCS locks use local data
- Reduce cache misses
 - Affinity scheduling: run process on the core where it last ran.
 - Avoid cache pollution

OS Design Guidelines for Modern (and future) Multiprocessors



- Avoid shared data
 - Performance issues arise less from lock contention than from data locality
- Explicit communication
 - Regain control over communication costs
 - Sometimes it's the only option
- Tradeoff: parallelism vs synchronisation
 - Synchronisation introduces serialisation
 - Make concurrent threads independent
- Allocate for locality
 - E.g. provide memory local to a core
- Schedule for locality
 - With cached data
 - With local memory
- Tradeoff: uniprocessor performance vs scalability

Design approaches



- Divide and conquer
 - Divide multiprocessor into smaller bits, use them as normal
 - Using virtualisation
 - Using exokernel
- Reduced sharing
 - Brute force & Heroic Effort
 - Find problems in existing OS and fix them
 - E.g Linux rearchitecting: BKL -> fine grained locking
 - By design
 - Avoid shared data as much as possible
- No sharing
 - Computer is a distributed system
 - Do extra work to share!

Divide and Conquer



Disco

Running commodity OSES on scalable multiprocessors [Bugnion et al., 1997]
<http://www-flash.stanford.edu/Disco/>

- Scalability is too hard!
- Context:
 - ca. 1995, large ccNUMA multiprocessors appearing
 - Scaling OSES requires extensive modifications
- Idea:
 - Implement a scalable VMM
 - Run multiple OS instances
- VMM has most of the features of a scalable OS:
 - NUMA aware allocator
 - Page replication, remapping, etc.
- VMM substantially simpler/cheaper to implement
- Modern incarnations of this
 - Virtual servers (Amazon, etc.)
 - Research (Cerberus)

Disco Architecture

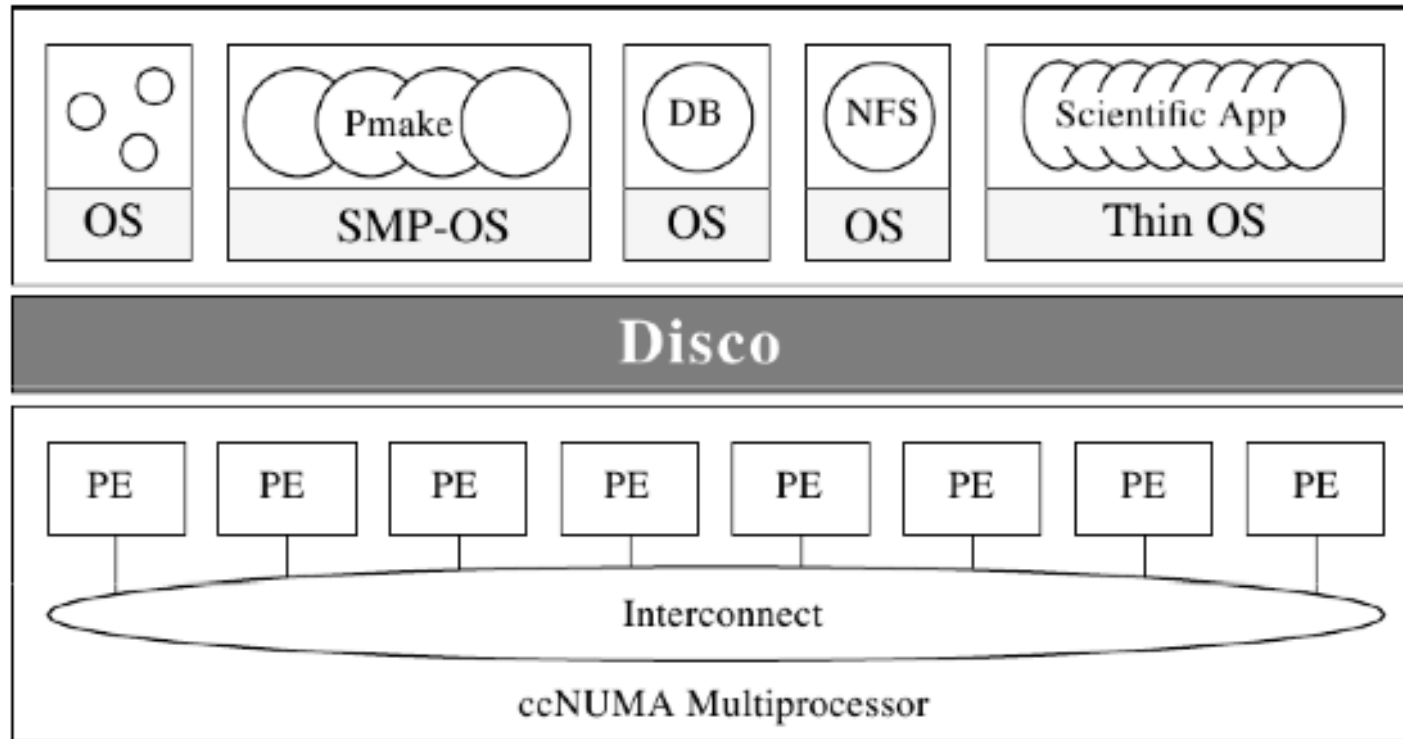

[Bugnion et al., 1997]

Disco Performance

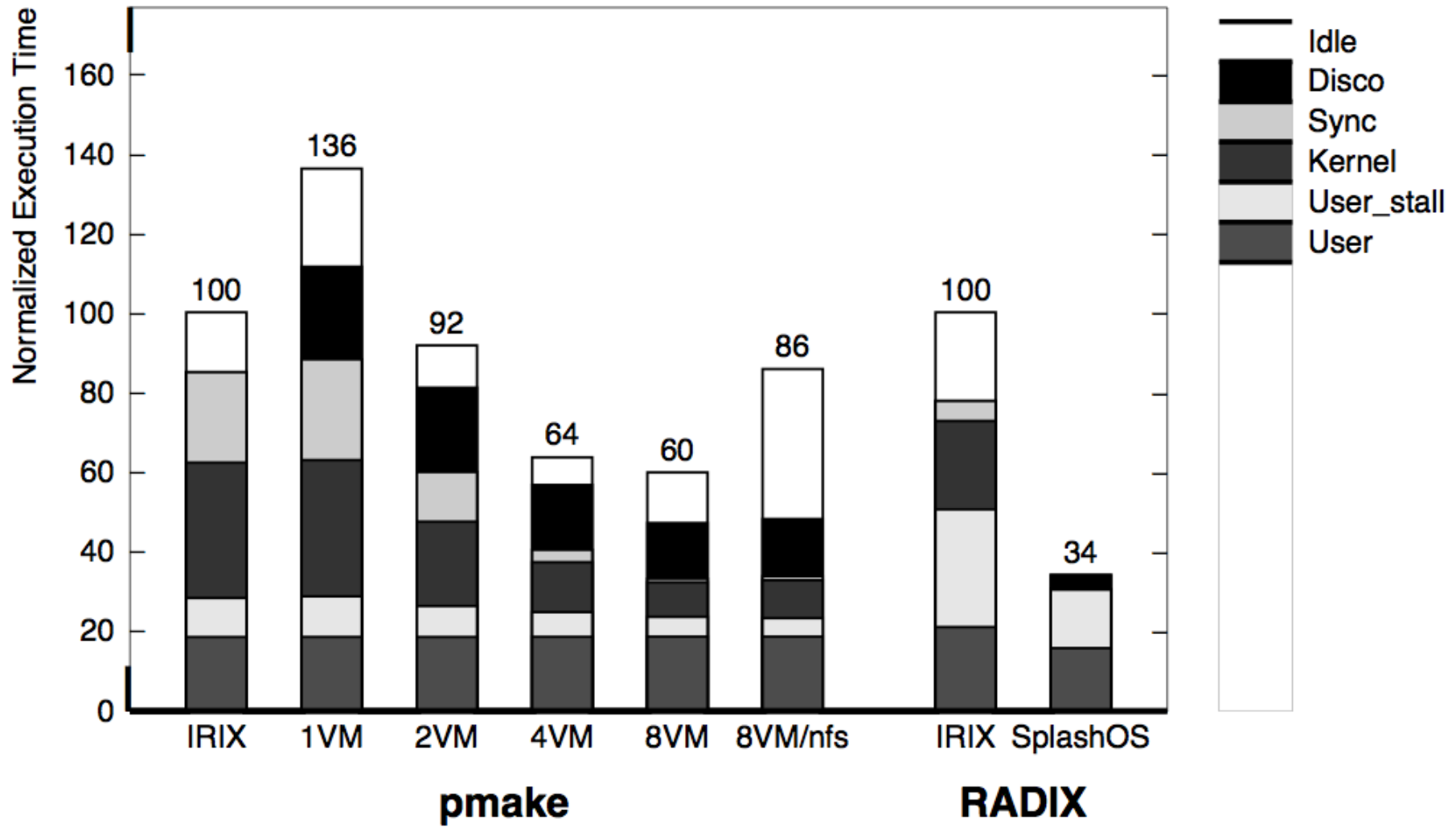

Space-Time Partitioning



Tessellation

Tessellation: Space-Time Partitioning in a Manycore Client OS [Liu et al., 2010]
<http://tessellation.cs.berkeley.edu/>

- Space-Time partitioning
- 2-level scheduling
- Context:
 - 2009-... highly parallel multicore systems
 - Berkeley Par Lab

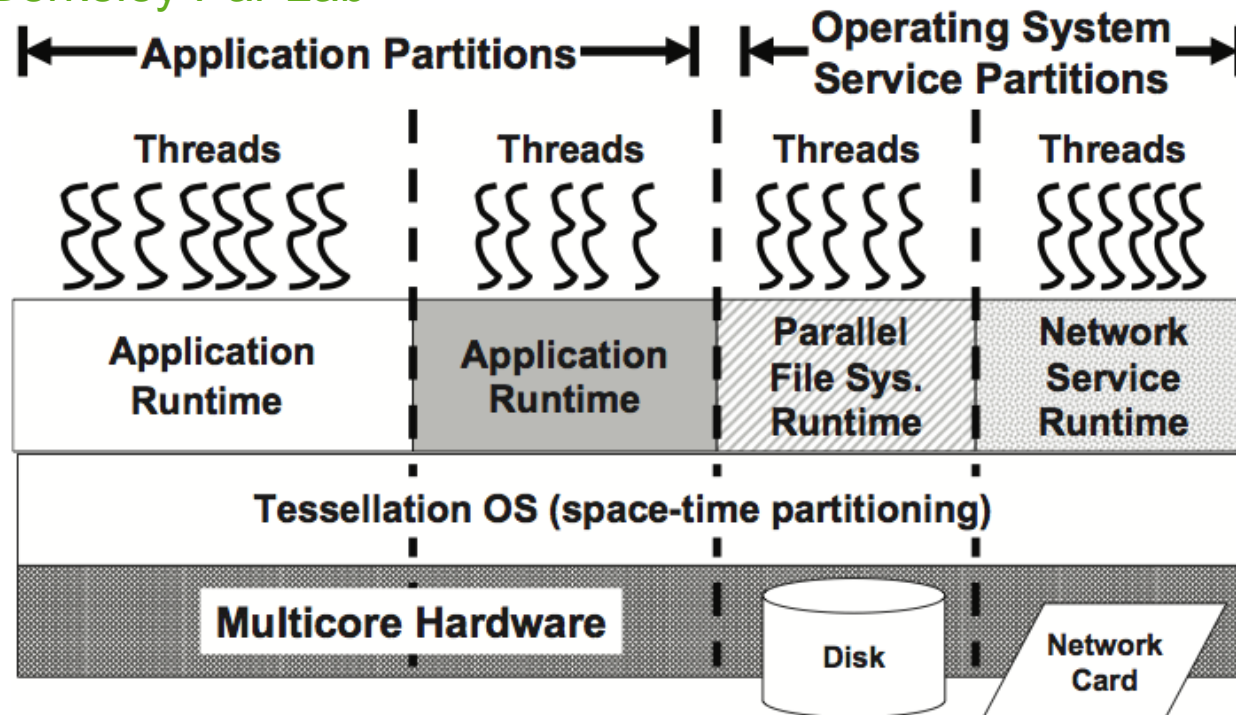

Tessellation

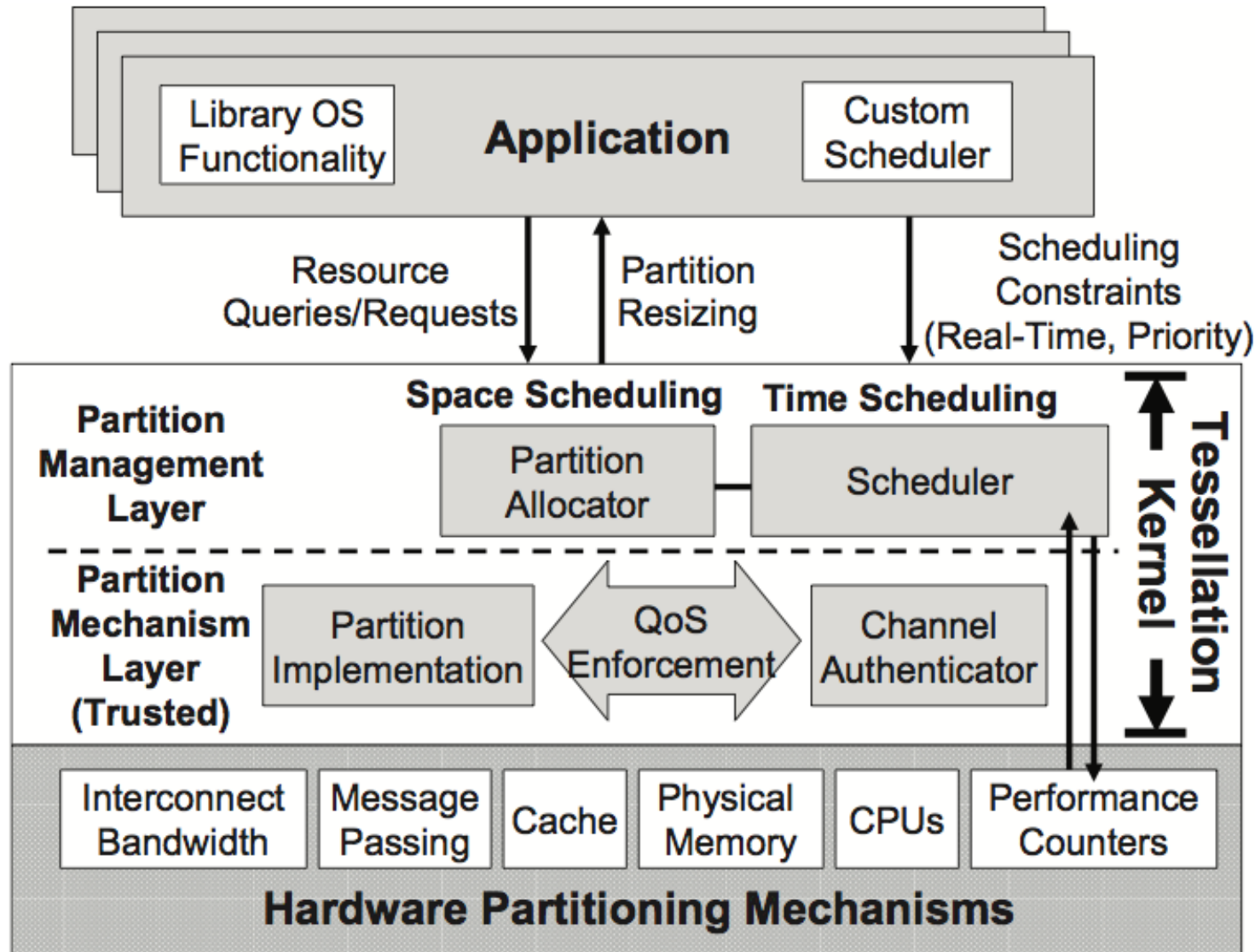

Reduce Sharing



K42

Clustered Objects, Ph.D. thesis [Appavoo, 2005]
<http://www.research.ibm.com/K42/>

- Context:
 - 1997-2006: OS for ccNUMA systems
 - IBM, U Toronto (Tornado, Hurricane)
- Goals:
 - High locality
 - Scalability
- Object Oriented
 - Fine grained objects
- Clustered (Distributed) Objects
 - Data locality
- Deferred deletion (RCU)
 - Avoid locking
- NUMA aware memory allocator
 - Memory locality

K42: Fine-grained objects

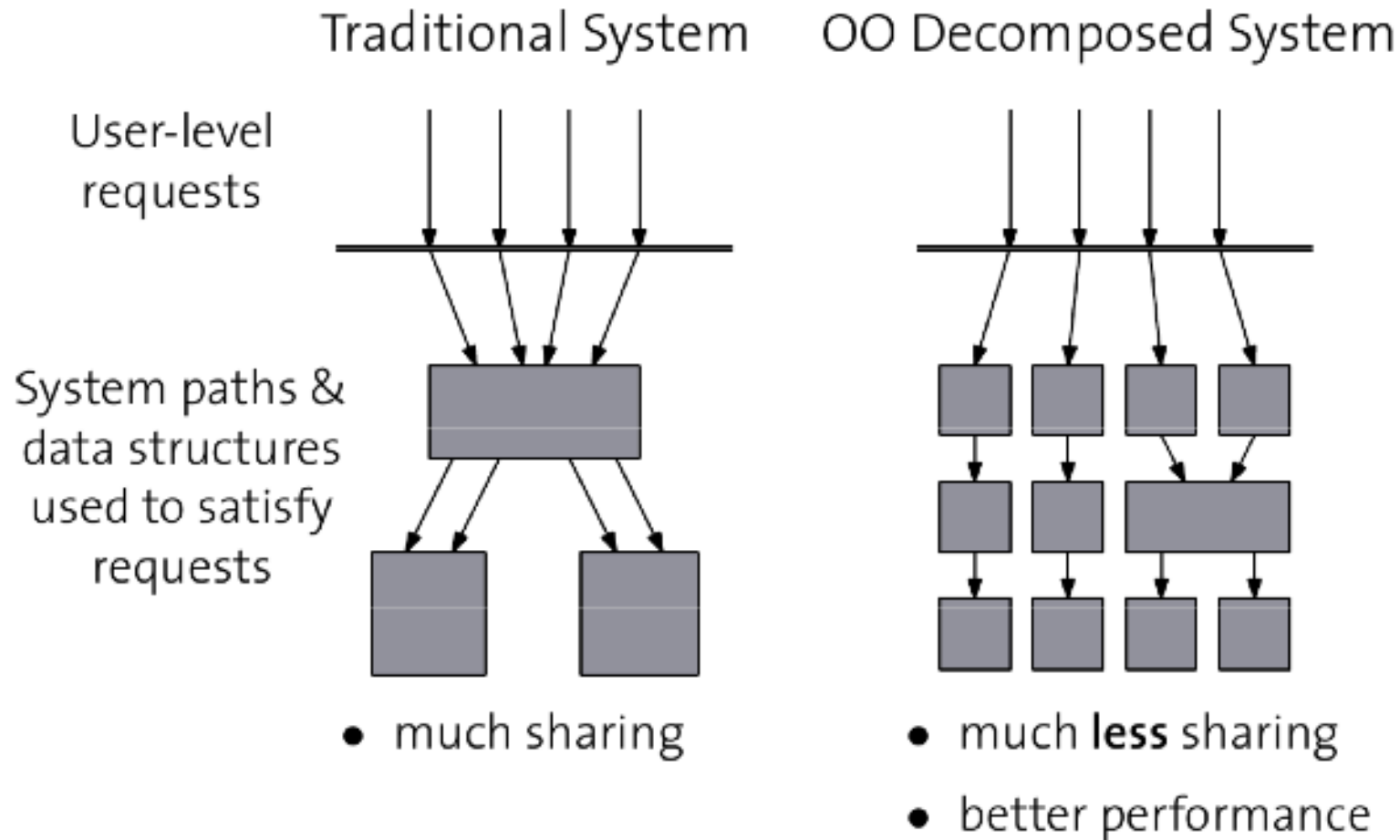

[Appavoo, 2005]

K42: Clustered objects

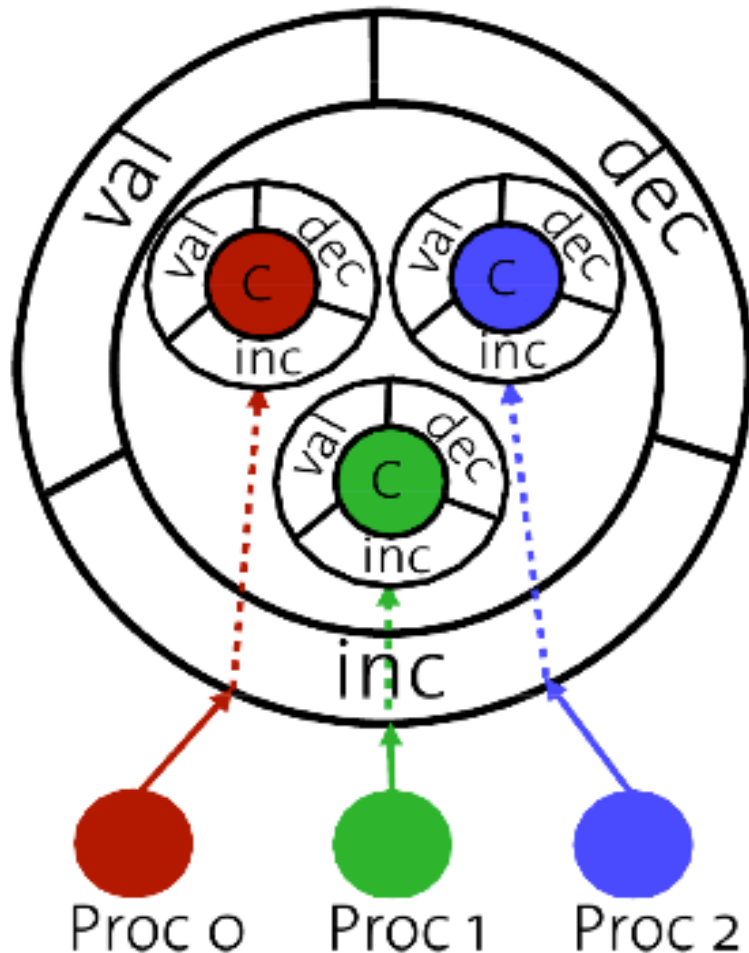

- Globally valid object reference
- Resolves to
 - Processor local representative
- Sharing, locking strategy local to each object
- Transparency
 - Eases complexity
 - Controlled introduction of locality
- Shared counter:
 - *inc, dec*: local access
 - *val*: communication
- Fast path:
 - Access mostly local structures

K42 Performance

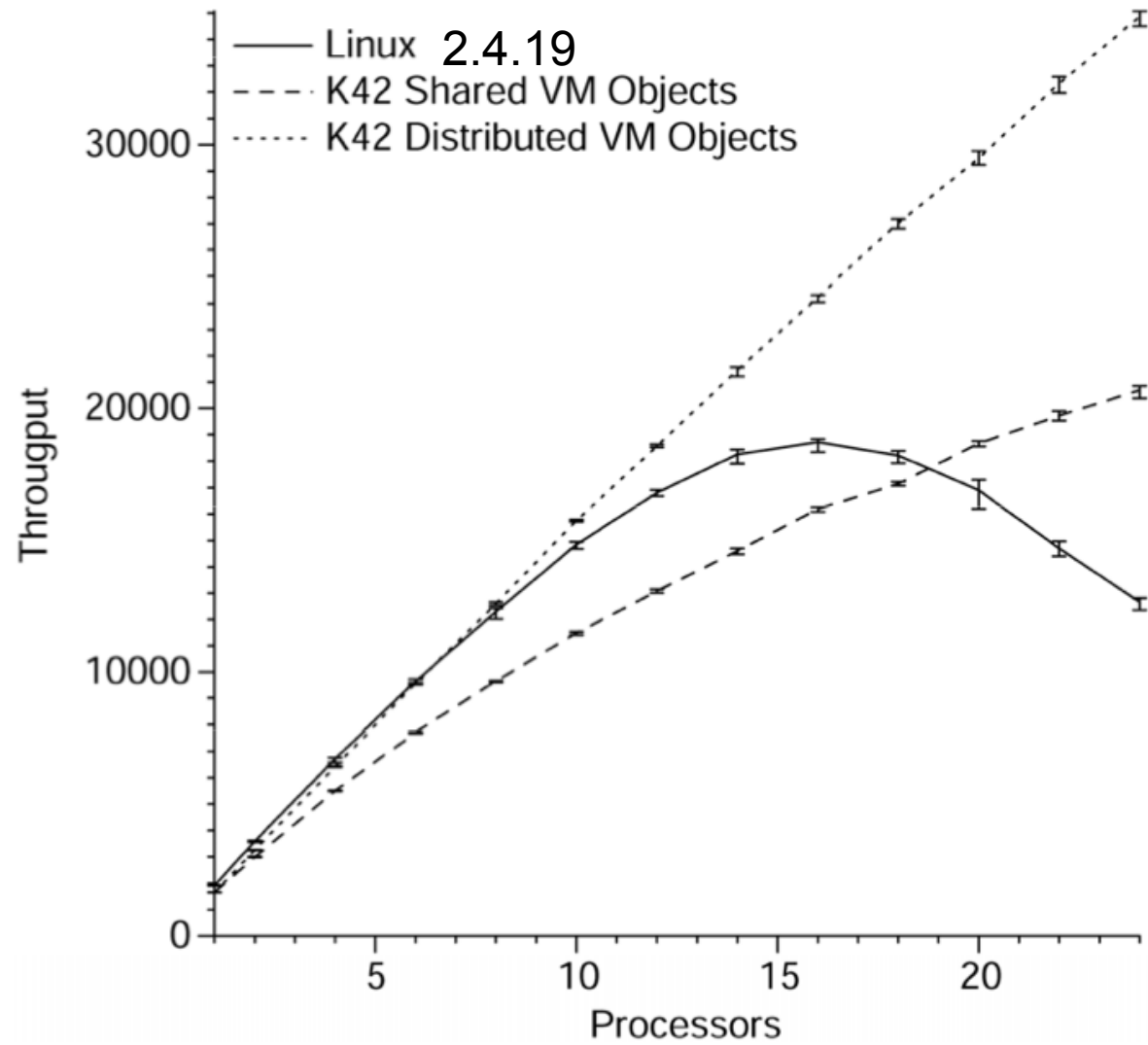

Corey



- Context
 - 2008, high-end multicore servers, MIT
- Goals:
 - Application control of OS sharing
- OS
 - Exokernel-like, higher-level services as libraries
 - By default only single core access to OS data structures
 - Calls to control how data structures are shared
- Address Ranges
 - Control private per core and shared address spaces
- Kernel Cores
 - Dedicate cores to run specific kernel functions
- Shares
 - Lookup tables for kernel objects allow control over which object identifiers are visible to other cores.

Linux Brute Force Scalability



- Context An Analysis of Linux Scalability to Many Cores [Boyd-Wickizer et al., 2010]
 - 2010, high-end multicore servers, MIT
- Goals:
 - Scaling commodity OS
- Linux scalability (2010 – scale Linux to 48 cores)

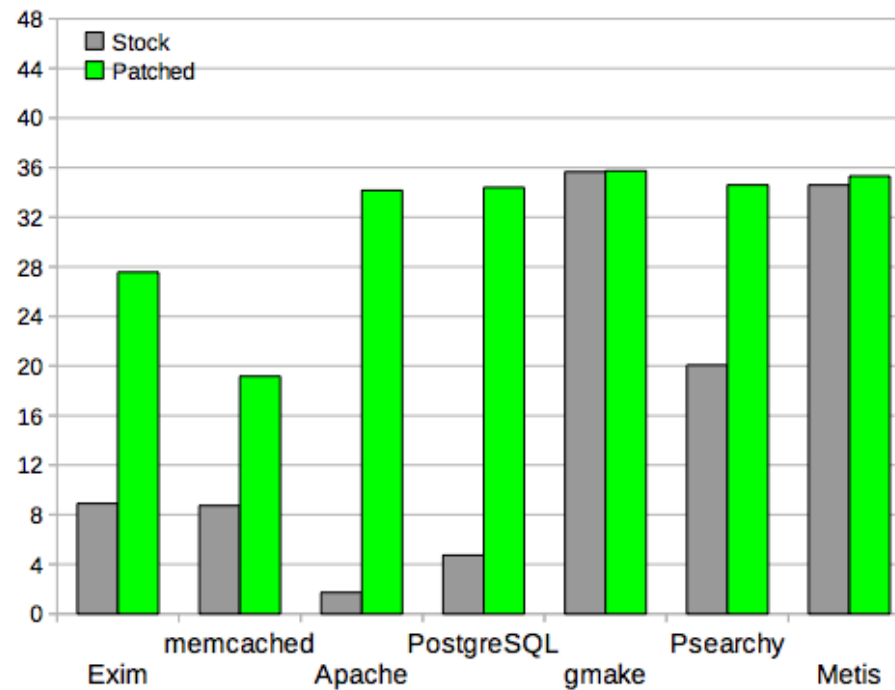

Y-axis: (throughput with 48 cores) / (throughput with one core)

Linux Brute Force Scalability



- Apply lessons from parallel computing and past research
 - sloppy counters,
 - per-core data structs,
 - fine-grained lock, lock free,
 - cache lines
 - 3002 lines of code changed

	memcached	Apache	Exim	PostgreSQL	gmake	Psearchy	Metis
Mount tables		X	X				
Open file table		X	X				
Sloppy counters	X	X	X				
inode allocation	X	X					
Lock-free dentry lookup		X	X				
Super pages							X
DMA buffer allocation	X	X					
Network stack false sharing	X	X		X			
Parallel accept		X					
Application modifications				X		X	X

- Conclusion:
 - no scalability reason to give up on traditional operating system organizations just yet.

Scalability of the API



- Context
 - 2013, previous multicore projects at MIT
- Goals
 - How to know if a system is really scalable?
- Workload-based evaluation
 - Run workload, plot scalability, fix problems
 - Did we miss any non-scalable workload?
 - Did we find all bottlenecks?
- Is there something fundamental that makes an system non-scalable?
 - The interface might be a fundamental bottleneck

The Scalable Commutativity Rule: Designing Scalable Software for Multicore Processors[Clements et al., 2013]

Scalable Commutativity Rule



- The Rule
 - *Whenever interface operations commute, they can be implemented in a way that scales.*
- Commutative operations:
 - Cannot distinguish order of operations from results
 - Example:
 - **Creat:**
 - Requires that lowest available FD be returned
 - Not commutative: can tell which one was run first
- Why are commutative operations scalable?
 - results independent of order \Rightarrow communication is unnecessary
 - without communication, no conflicts
- Informs software design process
 - Design: design guideline for scalable interfaces
 - Implementation: clear target
 - Test: workload-independent testing

Commuter: An Automated Scalability Testing Tool

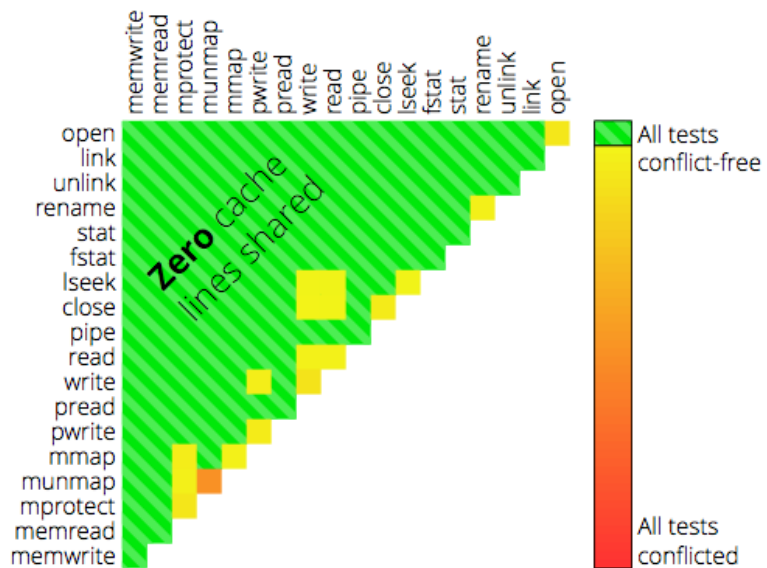
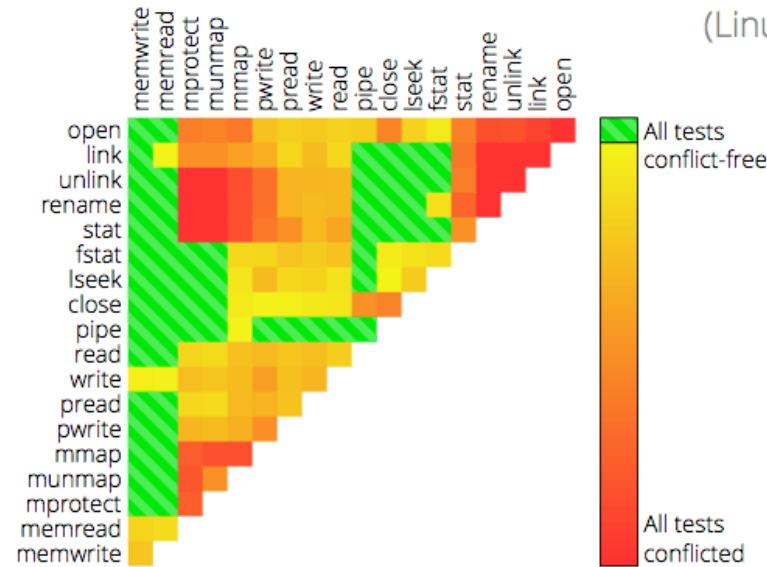
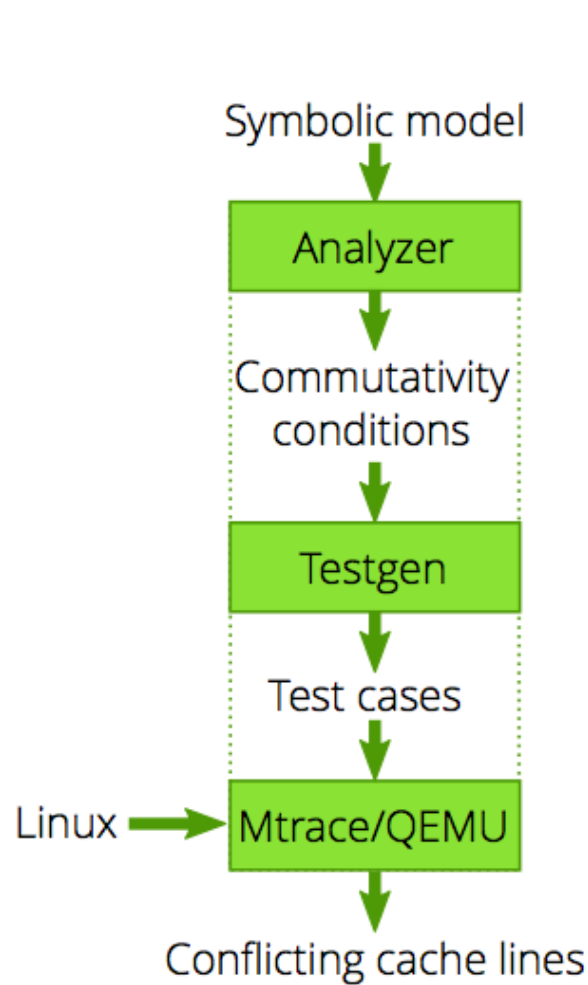

FlexSC



- **Context:** FlexSC: Flexible System Call Scheduling with Exception-Less System Calls [Soares and Stumm., 2010]
 - 2010, commodity multicores
 - U Toronto
- **Goal:**
 - Reduce context switch overhead of system calls
- **Syscall context switch:**
 - Usual mode switch overhead
 - But: cache and TLB pollution!

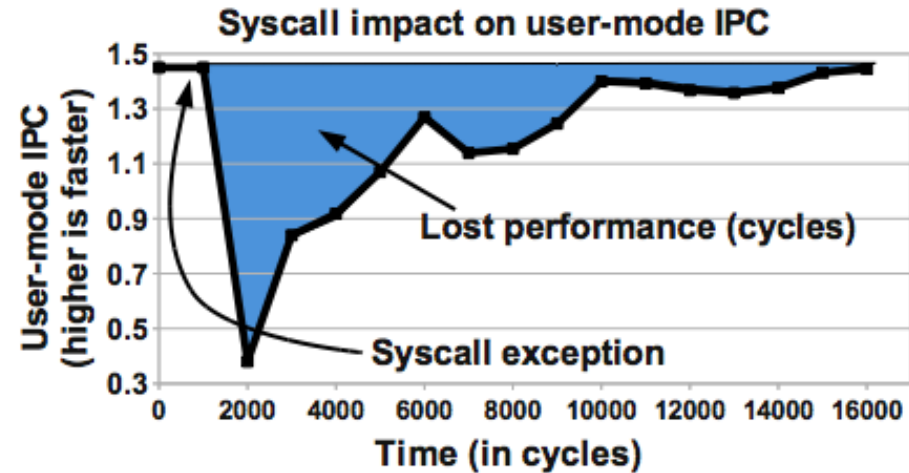

Syscall	Instructions	Cycles	IPC	i-cache	d-cache	L2	L3	d-TLB
stat	4972	13585	0.37	32	186	660	2559	21
pread	3739	12300	0.30	32	294	679	2160	20
pwrite	5689	31285	0.18	50	373	985	3160	44
open+close	6631	19162	0.34	47	240	900	3534	28
mmap+munmap	8977	19079	0.47	41	233	869	3913	7
open+write+close	9921	32815	0.30	78	481	1462	5105	49

FlexSC

- Asynchronous system calls
 - Batch system calls
 - Run them on dedicated cores
- FlexSC-Threads
 - M on N
 - M >> N

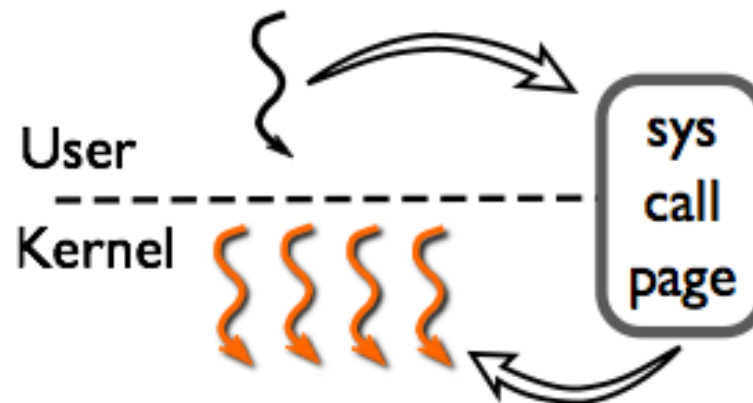

FlexSC Results

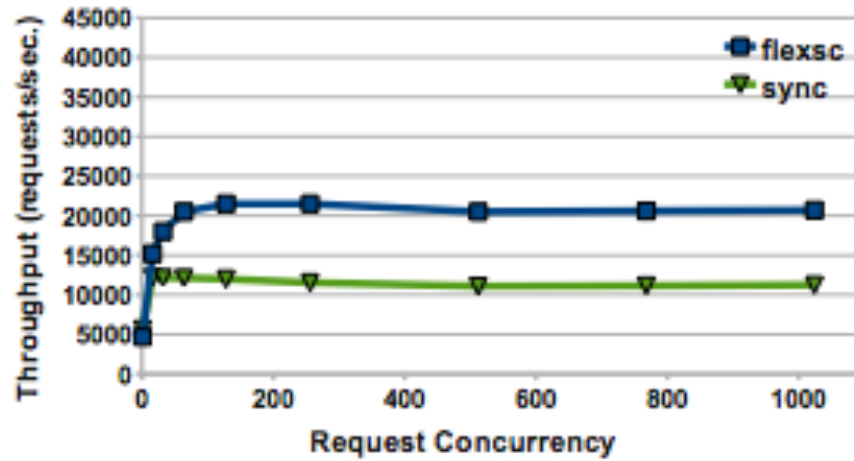

(a) 1 Core

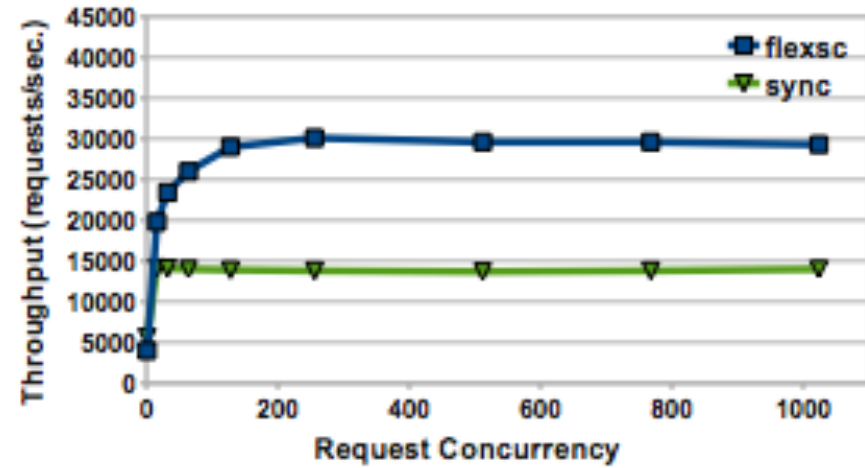

(b) 2 Cores

Apache
FlexSC: batching,
sys call core redirect

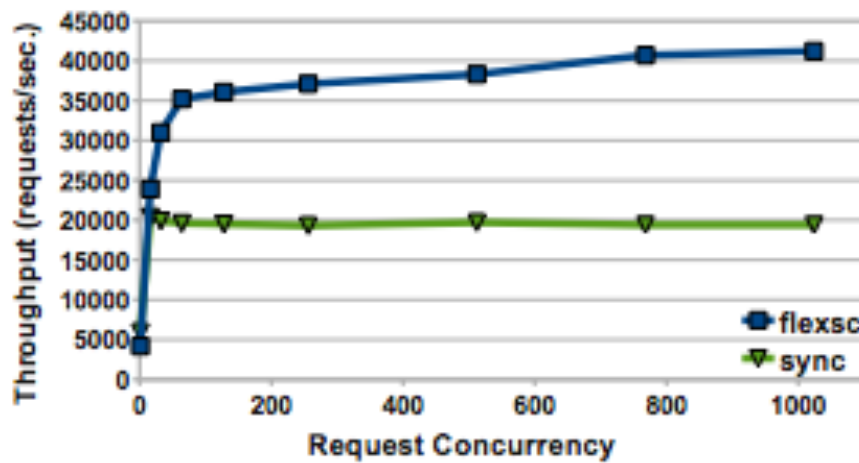

(c) 4 Cores

No sharing



- Multikernel
 - Barrelfish
 - fos: factored operating system

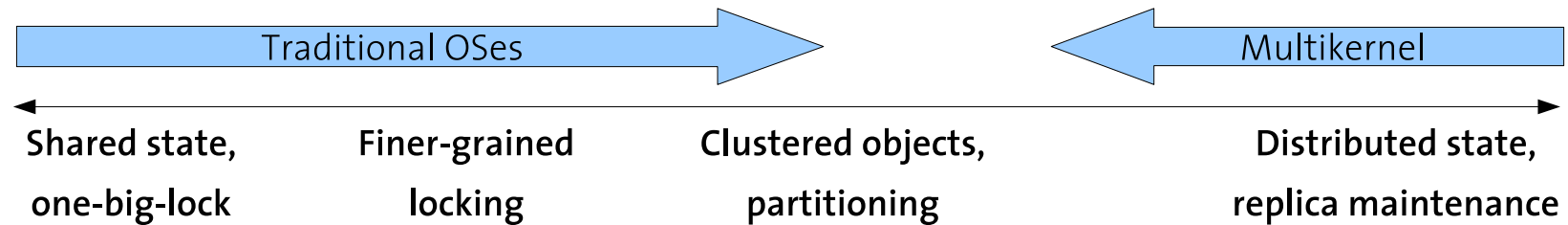

The Multikernel: A new OS architecture for scalable multicore systems [Baumann et al., 2009]
<http://www.barrelfish.org/>

Barrelfish



- **Context:** The Multikernel: A new OS architecture for scalable multicore systems [Baumann et al., 2009] <http://www.barrelfish.org/>
 - 2007 large multicore machines appearing
 - 100s of cores on the horizon
 - NUMA (cc and non-cc)
 - ETH Zurich and Microsoft
- **Goals:**
 - Scale to many cores
 - Support and manage heterogeneous hardware
- **Approach:**
 - Structure OS as *distributed system*
- **Design principles:**
 - Interprocessor communication is explicit
 - OS structure hardware neutral
 - State is replicated
- **Microkernel**
 - Similar to seL4: capabilities

Barrelfish

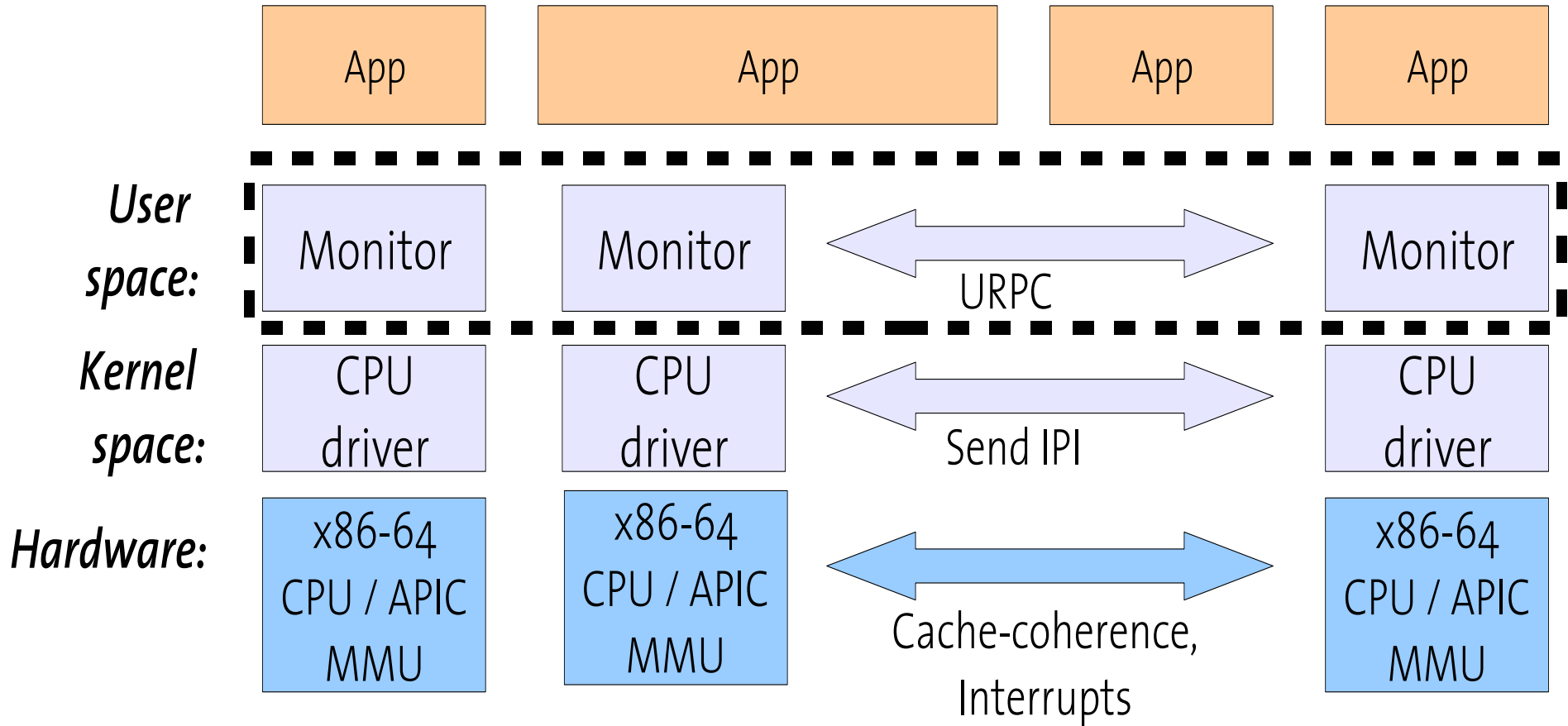

Barrelfish: Replication



- Kernel + Monitor:
 - Only memory shared for message channels
- Monitor:
 - Collectively coordinate system-wide state
- System-wide state:
 - Memory allocation tables
 - Address space mappings
 - Capability lists
- What state is replicated in Barrelfish
 - Capability lists
- Consistency and Coordination
 - Retype: two-phase commit to globally execute operation in order
 - Page (re/un)mapping: one-phase commit to synchronise TLBs

Barrelfish: Communication



- Different mechanisms:
 - Intra-core
 - Kernel endpoints
 - Inter-core
 - URPC
- URPC
 - Uses cache coherence + polling
 - Shared buffer
 - Sender writes a cache line
 - Receiver polls on cache line
 - (last word so no part message)
 - Polling?
 - Cache only changes when sender writes, so poll is cheap
 - Switch to block and IPI if wait is too long.

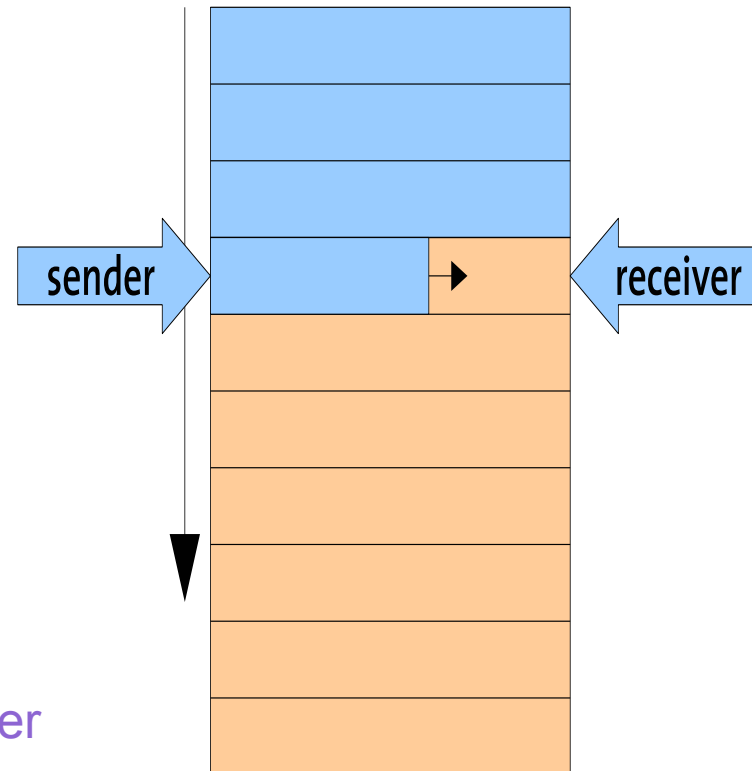

Barrelfish: Results



- Message passing vs caching

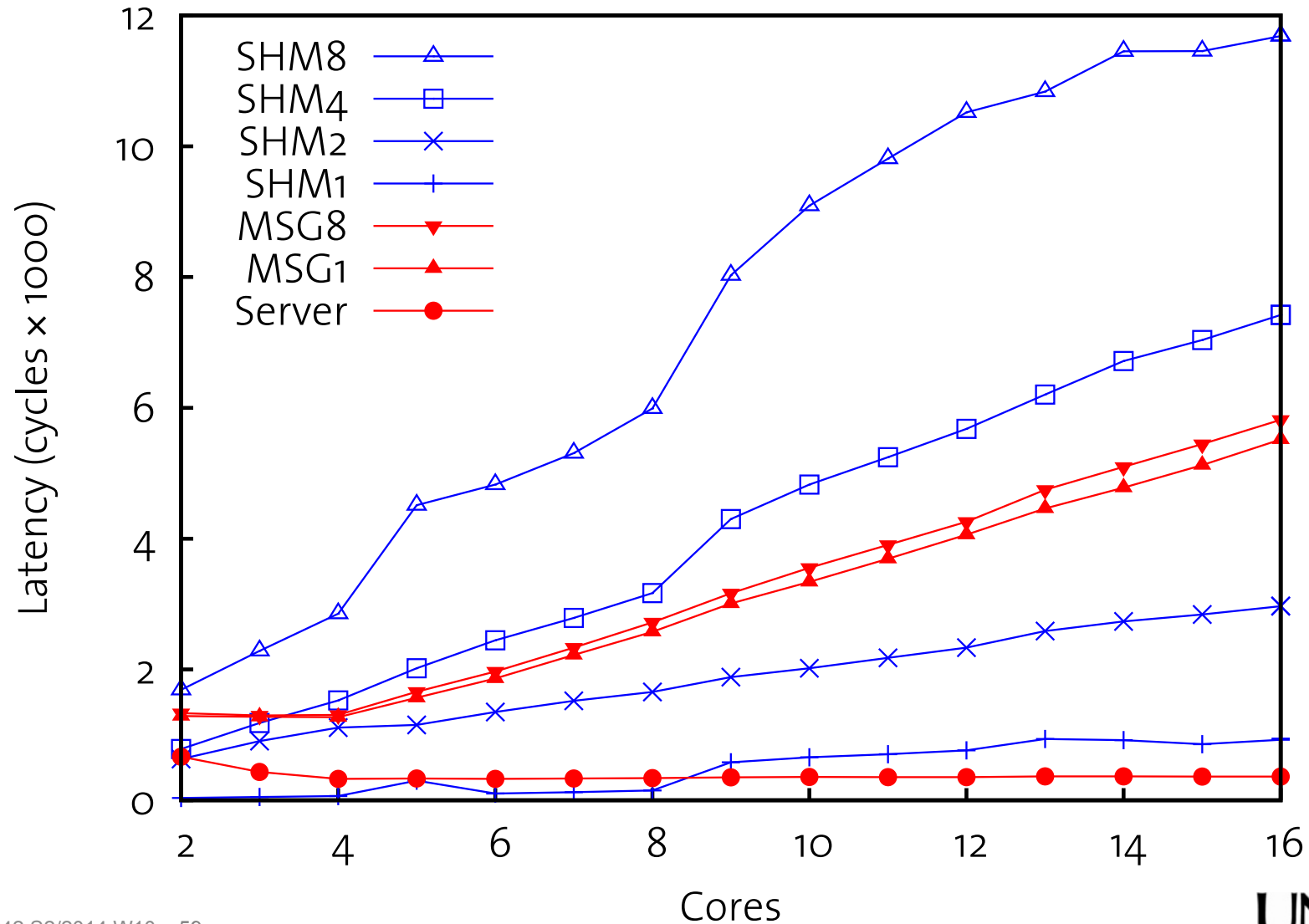

Barrelfish: Results



- Broadcast vs Multicast

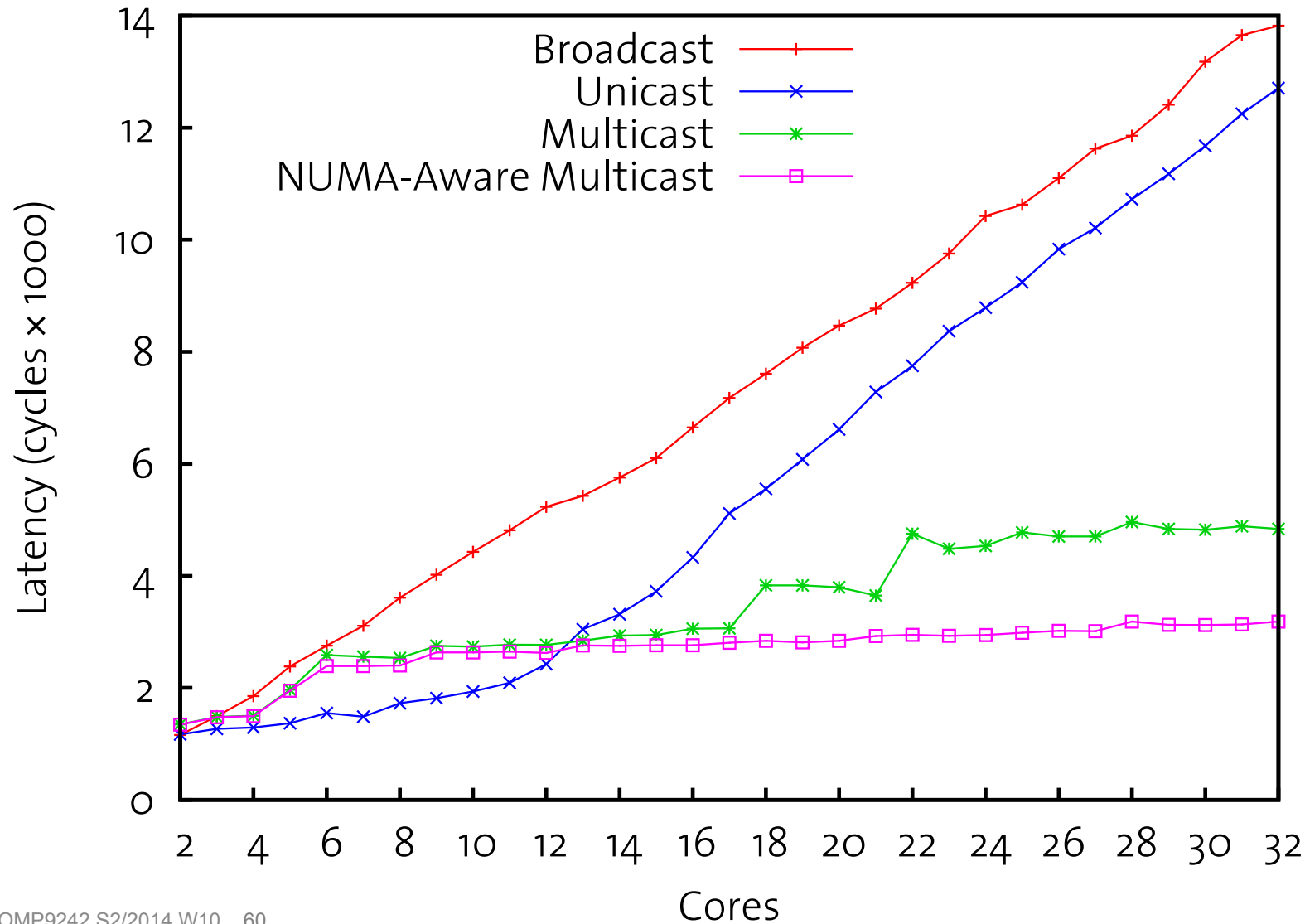

Barrelfish: Results



- TLB shutdown

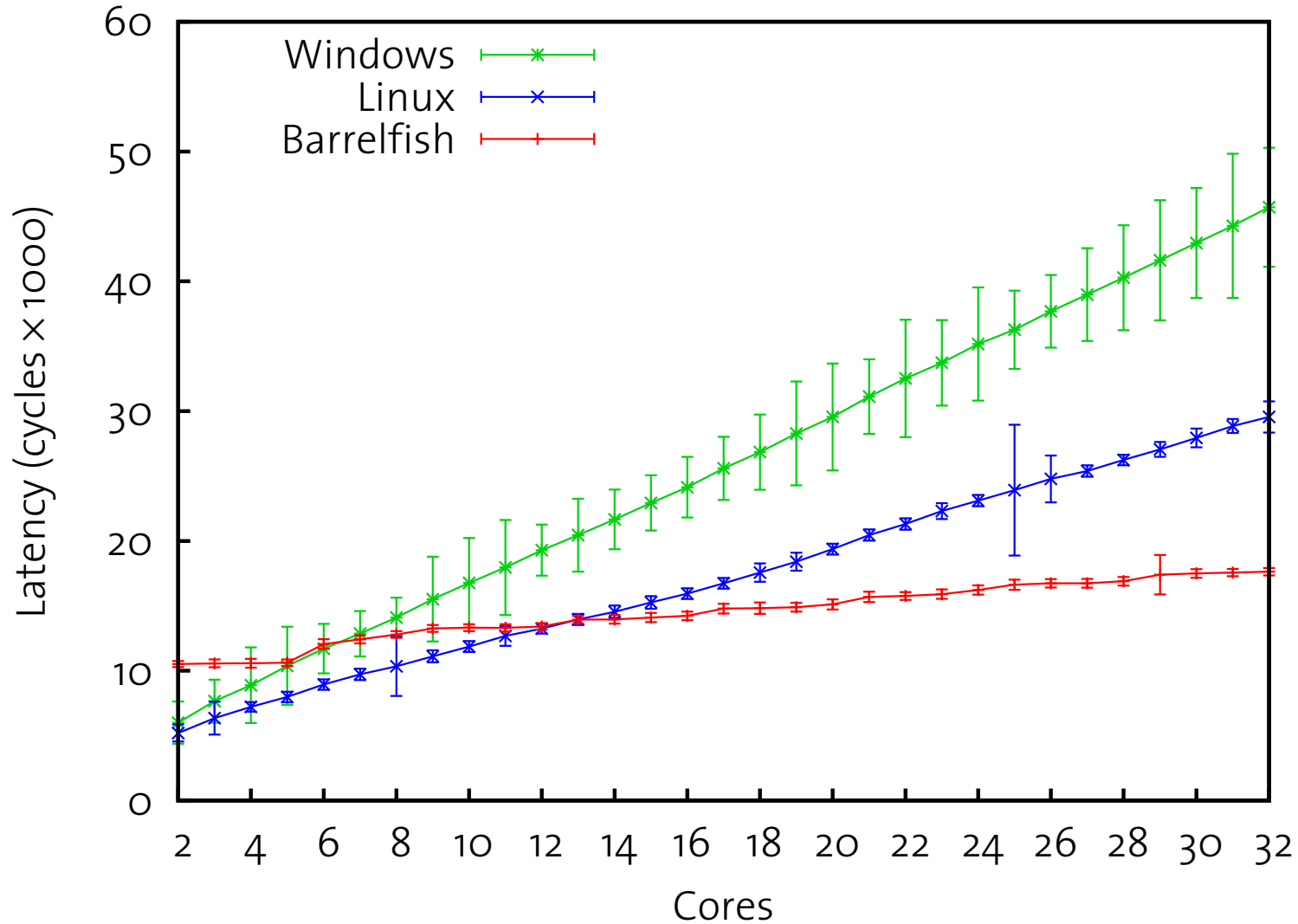

SUMMARY

Summary



- Trends in multicore
 - Scale (100+ cores)
 - NUMA
 - No cache coherence
 - Distributed system
 - Heterogeneity
- OS design guidelines
 - Avoid shared data
 - Explicit communication
 - Locality
- Approaches to multicore OS
 - Partition the machine (Disco, Tessellation)
 - Reduce sharing (K42, Corey, Linux, FlexSC)
 - No sharing (Barrelfish, fos)